

application. A new flow route was devised, involving passage of  $BX_3$  over solid  $NaBH_4$ ; this results in the almost quantitative formation of the  $HBX_2$  species ( $X = Cl, Br, \text{ and } F^{29}$ ), enabling them to be studied by UPS. This route should also prove useful for the study of these molecules by other spectroscopic methods. The observed ionization energies have been assigned by comparison with those of the known  $BX_3$  molecules, and with the aid of extended basis set ab initio calculations. The calculations also

serve to assist with an assessment of the relative total and  $\pi$  electronic charge distribution for the series  $BCl_3$ ,  $HBCl_2$ , and  $H_2BCl$ , which is relevant to the question of the Lewis acidity of these molecules.

**Acknowledgment.** The financial support of the Natural Sciences and Engineering Research Council of Canada is gratefully acknowledged.

## Phosphorus-Containing Cyclohexanes. Nuclear Magnetic Resonance Studies and Conformational Analysis of 1,3,2-Dithiaphosphorinanes<sup>1</sup>

Bruce E. Maryanoff,\*<sup>2a</sup> Andrew T. McPhail,<sup>2b</sup> and Robert O. Hutchins\*<sup>2c</sup>

Contribution from the Chemical Research Department, McNeil Pharmaceutical, Spring House, Pennsylvania 19477, The Paul M. Gross Chemical Laboratory, Duke University, Durham, North Carolina 27706, and the Department of Chemistry, Drexel University, Philadelphia, Pennsylvania 19104. Received November 11, 1980

**Abstract:** Proton, carbon-13, and phosphorus-31 NMR spectroscopic data were obtained for a variety of tricoordinate 1,3,2-dithiaphosphorinanes as well as tetracoordinate 2-oxo and 2-thiono derivatives. The tricoordinate compounds adopt a chair conformation in which an axial orientation is strongly preferred for many polar and nonpolar P substituents ( $CH_3$ ,  $C_2H_5$ ,  $C_6H_5$ ,  $OCH_3$ ,  $Cl$ ), but an equatorial orientation is strongly preferred for the *P-tert*-butyl group. The 2-oxo compounds show a tendency to populate a twist conformation in solution, but the 2-thiono compounds do not. Single-crystal X-ray analyses of 11 derivatives (**5**, **6**, **7a**, **11b**, **19**, **20a**, **22**, **23**, **24**, **28**, **31**) are employed to verify structural assignments and to provide solid-state conformational viewpoints. Three 2-oxo compounds (**5**, **6**, and **28**) adopt a twist conformation in the solid state. A chloride-catalyzed chlorine-exchange process in 2-chloro-1,3,2-dithiaphosphorinanes and the stereospecificity of certain <sup>1</sup>H and <sup>13</sup>C NMR parameters are discussed. A general discussion of twist preferences in 1,3,2-dithiaphosphorinanes, and congeneric systems, is presented.

The equilibrium between chair conformations of monosubstituted cyclohexanes (eq 1,  $M = CH$ )<sup>3,4</sup> and N-monosubstituted piperidines (eq 1,  $M = N$ )<sup>5</sup> favors the equatorial conformer, I, for almost every substituent (X) studied ( $A$  value =  $-\Delta G^\circ = RT \ln K > 0$ ). However, conformational preferences can be sub-

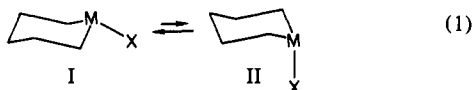

stantially reversed in saturated, six-membered heterocycles which contain, in place of  $CH-X$  or  $N-X$ , atoms from the second or third row of the periodic table,<sup>6</sup> such as sulfur ( $S-X$ ),<sup>7</sup> phosphorus

( $P-X$ ),<sup>8</sup> selenium ( $Se-X$ ),<sup>7i,9</sup> and arsenic ( $As-X$ ).<sup>10</sup>

In this connection, phosphorus-containing cyclohexanes have received considerable attention over the past decade.<sup>11</sup> Tricoordinate 1,3,2-dioxaphosphorinanes and 1,3,2-dithiaphosphorinanes exhibit axial preferences for both nonpolar (e.g.,  $CH_3$ ,  $C_6H_5$ ) and polar (e.g.,  $Cl$ ,  $OCH_3$ ) phosphorus substituents; phosphorinanes exhibit axial preferences for nonpolar groups at normal temperatures.<sup>11</sup> The reversal of energetics by introduction of tricoordinate phosphorus into a six-membered ring is dramatically illustrated by comparison<sup>11</sup> of free-energy values ( $-\Delta G^\circ$ ) for **1** (3.1 kcal/mol)<sup>12</sup> and **2** ( $\sim -1.2$ ),<sup>13</sup> and for **3** (1.7)<sup>4</sup> and **4** ( $\sim -0.4$ ).<sup>8a,8b</sup>

Our NMR studies,<sup>14</sup> and those of Robert and co-workers,<sup>15</sup> on tricoordinate 1,3,2-dithiaphosphorinanes have established that the ring adopts a chair conformation and that an axial orientation for phosphorus substituents strongly predominates for  $C_6H_5$ ,  $OCH_3$ ,  $Cl$ ,  $CH_3$ ,  $C_2H_5$ , and 1-aziridinyl groups; an equatorial orientation is highly favored for *t*- $C_4H_9$  and bulky dialkylamino

(1) Presented in part at the International Conference on Phosphorus Chemistry, Halle, East Germany, September, 1979. Portions of this work were derived from the Ph.D. Dissertation of B.E.M., Drexel University, 1972.

(2) (a) McNeil Pharmaceutical (formerly McNeil Laboratories, Fort Washington, PA); (b) Duke University; (c) Drexel University.

(3) Eliel, E. L.; Allinger, N. L.; Angyal, S. J.; Morrison, G. A., "Conformational Analysis", Wiley, New York, 1965.

(4) Hirsch, J. A.; *Top. Stereochem.*, **1**, 199 (1967).

(5) (a) Eliel, E. L.; Vierhapper, F. W., *J. Am. Chem. Soc.*, **97**, 2424 (1975); (b) Robinson, M. J. T., *J. Chem. Soc., Chem. Commun.*, 844 (1975); (c) Appleton, D. C.; McKenna, J.; Sim, L. B.; Walley, A. R., *J. Am. Chem. Soc.*, **98**, 292 (1976); (d) Lambert, J. B.; Oliver, W. L., Jr.; Packard, B. S., *J. Am. Chem. Soc.*, **93**, 333 (1971); (e) Anet, F. A. L.; Yavari, I., *J. Am. Chem. Soc.*, **99**, 2794 (1977).

(6) Lambert, J. B.; Featherman, S. I., *Chem. Rev.*, **75**, 611 (1975).

(7) (a) Eliel, E. L.; Willer, R. L.; McPhail, A. T.; Onan, K. D., *J. Am. Chem. Soc.*, **96**, 3021 (1974); (b) Eliel, E. L.; Willer, R. L.; *J. Am. Chem. Soc.*, **99**, 1936 (1977); (c) Lambert, J. B.; Bailey, D. S.; Mixan, C. E., *J. Org. Chem.*, **37**, 377 (1972); (d) Lambert, J. B.; Keske, R. G.; Weary, D. K., *J. Am. Chem. Soc.*, **89**, 5921 (1967); (e) Lambert, J. B.; Bailey, D. S.; Keske, R. G., *J. Org. Chem.*, **31**, 3429 (1966); (f) Lambert, J. B.; Mixan, C. E.; Bailey, D. S., *Chem. Commun.*, 316 (1971); (g) Johnson, C. R.; McCants, D. B., Jr., *J. Am. Chem. Soc.*, **87**, 1109 (1965); (h) Martin, J. C.; Uebel, J. J., *J. Am. Chem. Soc.*, **86**, 2936 (1964); (i) Lambert, J. B.; Mixan, C. E.; Johnson, D. H., *J. Am. Chem. Soc.*, **95**, 4634 (1973).

(8) (a) Featherman, S. I.; Quin, L. D., *J. Am. Chem. Soc.*, **95**, 1699 (1973); (b) Featherman, S. I.; Quin, L. D., *J. Am. Chem. Soc.*, **97**, 4349 (1975); (c) Lambert, J. B.; Oliver, W. L., Jr., *Tetrahedron*, **27**, 4245 (1971).

(9) Lambert, J. B.; Mixan, C. E.; Johnson, D. H., *Tetrahedron Lett.*, 4335 (1972).

(10) (a) Lambert, J. B.; Netzel, D. A.; Sun, H.-N.; Lilianstrom, K. L., *J. Am. Chem. Soc.*, **98**, 3778 (1976); (b) Lambert, J. B.; Sun, H.-N., *J. Organometal. Chem.*, **117**, 17 (1976).

(11) Maryanoff, B. E.; Hutchins, R. O.; Maryanoff, C. A., *Top. Stereochem.*, **11**, 187 (1979).

(12) (a) Eliel, E. L.; Knoeber, M. C., *J. Am. Chem. Soc.*, **90**, 3444 (1968); (b) Nader, F. W.; Eliel, E. L., *J. Am. Chem. Soc.*, **92**, 3050 (1970).

(13) Bentrude, W. G.; Tan, H. W.; Yee, K. C., *J. Am. Chem. Soc.*, **97**, 573 (1975).

(14) Hutchins, R. O.; Maryanoff, B. E., *J. Am. Chem. Soc.*, **94**, 3266 (1972).

(15) (a) Martin, J.; Robert, J. B.; Taleb, C., *J. Phys. Chem.*, **80**, 2417 (1976); (b) Martin, J.; Robert, J. B., *Org. Magn. Reson.*, **7**, 76 (1975).

Table I.  $^1\text{H}$  NMR Data for 5-*tert*-Butyl-1,3,2-dithiaphosphorinanes<sup>a</sup>

compd	$\delta$ <i>t</i> -Bu	$\delta$ H <sub>k</sub>	$\delta$ H <sub>a</sub>	$\delta$ H <sub>b</sub>	$J_{ab}$	$J_{ak}$	$J_{bk}$	$J_{ax}$	$J_{bx}$
7a <sup>b,c</sup>	0.76	1.91	2.49	2.68	-13.5	10.5	1.8	1.6	0
7a <sup>d</sup>	0.41	~1.9		2.45	<i>e</i>	$(J_{ak} + J_{bk})/2 = 6$		<i>e</i>	<i>e</i>
8a <sup>c</sup>	0.95	1.98	3.14	2.77	-13.8	10.8	2.5	2.4	0
9a <sup>c</sup>	0.94	~1.9	3.00	2.82					
9a <sup>d,f</sup>	0.49	1.76	2.58	2.40	-13.8	10.6	2.5	2.0	0

<sup>a</sup> Chemical shifts are in parts per million downfield from Me<sub>4</sub>Si; coupling constants are in hertz ( $\pm 0.3$  Hz). <sup>b</sup>  $J_{kx} \cong 3.0$  Hz;  $J_{bb'} < 0.5$  Hz. <sup>c</sup> In CDCl<sub>3</sub>. <sup>d</sup> In benzene-d<sub>6</sub>. <sup>e</sup> Indeterminate. <sup>f</sup> The same coupling constants were observed in CDCl<sub>3</sub>.

groups. Our recent studies<sup>16</sup> on an isomeric pair of 2-oxo-1,3,2-dithiaphosphorinanes, **5** and **6**, revealed a propensity for adoption of a twist conformation in both solution (for **6**)<sup>16a</sup> and in the solid state (for **5** and **6**).<sup>16b</sup> The observation of low-energy twist

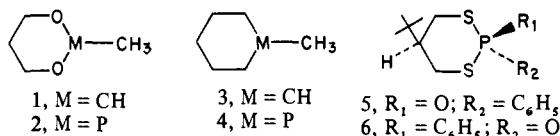

conformations for the tetracoordinate compounds **5** and **6** adds to the intriguing conformational properties of tri- and tetracoordinate 1,3,2-dithiaphosphorinanes. In this paper we present complete details of our solution studies on this heterocyclic system. This work includes  $^1\text{H}$ ,  $^{13}\text{C}$ , and  $^{31}\text{P}$  NMR spectroscopic analyses. We have examined 2-oxo derivatives unbiased by substitution at ring positions 4, 5, or 6 in a search for possible unconstrained twist conformers in solution. X-ray determinations for eleven 1,3,2-dithiaphosphorinanes, the details of which will be presented in a separate paper,<sup>17</sup> are used to verify structural assignments and to provide solid-state conformational viewpoints.

## Results and Discussion

**Synthesis.** The 1,3,2-dithiaphosphorinanes employed in this study were prepared by condensation of substituted 1,3-propanedithiols<sup>18</sup> with appropriate dichlorophosphines, dichlorophosphine oxides, or dichlorophosphine sulfides in the presence of triethylamine (eq 2). Also, 2-oxo- and 2-thiono derivatives

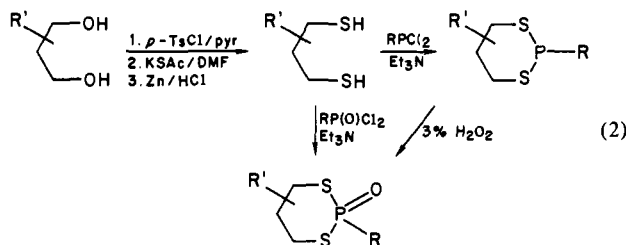

were obtained by oxidation or sulfurization of tricoordinate 1,3,2-dithiaphosphorinanes (eq 2).

**$^1\text{H}$  NMR Spectra and Stereochemistry of Tricoordinate Compounds.** 1,3-Diheterocyclohexanes are readily amenable to  $^1\text{H}$  NMR analysis. With phosphorus present, spin interaction of the  $^{31}\text{P}$  nucleus complicates the spectra; however, the  $^{31}\text{P}$ -H coupling constants provide valuable structural information.<sup>11</sup> Our  $^1\text{H}$  NMR studies were mainly conducted on tricoordinate 1,3,2-dithiaphosphorinanes with conformationally biasing substituents, 5-*tert*-butyl (**7a**-**9a**) and *cis*-4,6-dimethyl (**11a**, **11b**), on the ring carbons; we also studied 5,5-dimethyl derivatives, which are unbiased by substitution on the ring carbons.

The  $^1\text{H}$  NMR spectrum of the more stable isomer of **7** (**7a**) in CDCl<sub>3</sub> at 220 MHz revealed an approximately first-order

AA'BB'KX pattern (X =  $^{31}\text{P}$ ):  $\delta$  1.91 (H<sub>k</sub>, br t), 2.49 (H<sub>a</sub>, br d of d), 2.68 (H<sub>b</sub>, br d). Expansion of the ABK region allowed

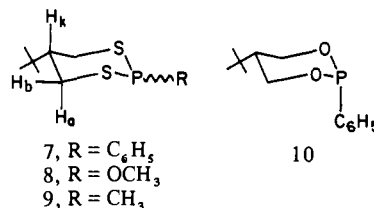

extraction of coupling parameters: H<sub>k</sub> (d of t of t)  $J_{ak} = 10.5 \pm 0.5$  Hz,  $J_{bk} = 1.7$ -2.0 Hz,  $J_{kx} = \sim 3$  Hz; H<sub>a</sub> (d of d of d)  $J_{ab} = 13.4 \pm 0.5$  Hz,  $J_{ax} = 1.5$ -1.8 Hz,  $J_{ak}$ ; H<sub>b</sub> (d of d)  $J_{bx} = 0$  Hz,  $J_{bk}$ ,  $J_{ab}$ . The assignment of H<sub>a</sub> at higher field than H<sub>b</sub> derives from the values of their coupling with H<sub>k</sub>. The  $J_{ak}$ ,  $J_{bk}$  and  $J_{ax}$ ,  $J_{bx}$  sets were easily distinguished without resorting to  $^{31}\text{P}$ -H spin decoupling or deuterium substitution for H<sub>k</sub> because the sole large coupling (exclusive of  $J_{ab}$ ) had to be  $J_{ak}$  and the zero coupling had to be a vicinal  $^{31}\text{P}$ -H coupling. The four-bond coupling,  $J_{kx}$ , of 3.0 Hz is unusually large compared to values of around 0.5-1.0 Hz in 1,3,2-dioxaphosphorinanes<sup>13</sup> and 1,3,2-diazaphosphorinanes.<sup>19</sup> A similar observation has been reported for 1,3,2-dithiaphosphorinanes by Robert and co-workers.<sup>15,20</sup>

Average experimental parameters were used as input for the iterative NMR computer program LAOCOON 3,<sup>21</sup> calculated and experimental spectra were matched by altering selected parameters. No attempt was made to determine fine splittings (<1 Hz) precisely from cross-ring, long-range, proton-proton spin interactions. The final, computed coupling constants were only slightly different from those read directly from the spectra:  $J_{ab} = -13.8$  Hz,  $J_{ak} = 10.8$  Hz,  $J_{ax} = 2.4$  Hz,  $J_{bk} = 2.3$  Hz,  $J_{bx} = 0$  Hz,  $J_{kx} = 3.0$  Hz,  $J_{bb'} = -0.7$  Hz,  $J_{aa'} = 0$  Hz, and  $J_{a'b} = 0$  Hz.

From the syntheses of **8** and **9**, only major (a) isomers were separated and purified; minor (b) isomers were again elusive. It is evident from  $^1\text{H}$  NMR data for **7a**-**9a** (Table I), especially the vicinal H-H coupling constants, that the SC<sub>4</sub>C<sub>5</sub>C<sub>6</sub>S portion of the ring assumes an essentially rigid chair conformation with the 5-*tert*-butyl group equatorial.

$^{31}\text{P}$ -H spin interactions show defined geometric relationships in conformationally biased 1,3,2-dioxaphosphorinanes:  $^3J_{\text{POCH}(\text{eq})}$  is large ( $\sim 11$  Hz) and  $^3J_{\text{POCH}(\text{ax})}$  is small ( $\sim 3$  Hz).<sup>11</sup> By contrast, in **7a**-**9a** both  $^3J_{\text{PSCCH}}$  values are small and the axial coupling is larger than the equatorial coupling; a constant geometric relationship is evident. The small  $^3J_{\text{PSCCH}}$  values compared to the  $^4J_{\text{PSCCH}}$  values is a reversal of what is generally seen for  $^3J_{\text{POCH}}$  vs.  $^4J_{\text{POCCH}}$  in 1,3,2-dioxaphosphorinanes<sup>11,13</sup> and for  $^3J_{\text{PSCCH}}$  vs.  $^4J_{\text{PSCCH}}$  in acyclic derivatives.<sup>22</sup> It is interesting to note that the near-zero coupling for  $^4J_{\text{PSCCH}}$  in a situation of conformational averaging [e.g., in P(SCH<sub>2</sub>CH<sub>3</sub>)<sub>3</sub>] may be a consequence of

(19) Hutchins, R. O.; Maryanoff, B. E.; Albrand, J. P.; Cogne, A.; Gagnaire, D.; Robert, J. B., *J. Am. Chem. Soc.*, **94**, 9151 (1972).

(20) The four-bond coupling constant ( $^4J_{\text{PSCCH}}$ ) is quite large (8-10 Hz) for the equatorial 5-proton in chair conformations with axial P substituents; the range of  $^4J_{\text{PSCCH}}$  for the axial 5-proton in these conformers is 2.5-4 Hz.<sup>15</sup> In chair conformations with equatorial P substituents  $^4J_{\text{PSCCH}(\text{ax})}$  is 1-2 Hz and  $^4J_{\text{PSCCH}(\text{eq})}$  is  $\sim 1$  Hz.<sup>15</sup> These long-range couplings can serve a diagnostic function in conformational analysis.

(21) Castellano, J.; Sun, C.; Kostelnik, R., *J. Chem. Phys.*, **46**, 327 (1967).

(22)  $^1\text{H}$  NMR spectra of C<sub>6</sub>H<sub>5</sub>P(SC<sub>2</sub>H<sub>5</sub>)<sub>2</sub> and (C<sub>2</sub>H<sub>5</sub>S)<sub>3</sub>P reveal a  $^3J_{\text{PSCCH}}$  of 7.5 Hz and a  $^4J_{\text{PSCCH}}$  of  $\sim 0.5$  Hz.

(16) (a) Maryanoff, B. E.; Hutchins, R. O., *J. Org. Chem.*, **42**, 1022 (1977); (b) Hutchins, R. O.; Maryanoff, B. E.; Castillo, M. J.; Hargrave, K. D.; McPhail, A. T., *J. Am. Chem. Soc.*, **101**, 1600 (1979).

(17) Castillo, M. J.; Hargrave, K. D.; McPhail, A. T.; Onan, K. D.; Hutchins, R. O.; Maryanoff, B. E., manuscript to be submitted for publication.

(18) (a) Eliel, E. L.; Hutchins, R. O., *J. Am. Chem. Soc.*, **91**, 2703 (1969); (b) Eliel, E. L.; Rao, V. S.; Smith, S.; Hutchins, R. O., *J. Org. Chem.*, **40**, 524 (1975).

Table II.  $^1\text{H}$  NMR Data for 5,5-Dimethyl-1,3,2-dithiaphosphorinanes<sup>a</sup>

compd	solvent	$\delta$ Me(q)	$\delta$ Me(t)	$\delta$ H(a)	$\delta$ H(b)	$^3J_{\text{Pa}}$	$^3J_{\text{Pb}}$	$J_{\text{ab}}$
12	$\text{CDCl}_3$	1.30	0.80	2.56	2.14	2.5	0.0	-14.0
	$\text{C}_6\text{D}_6$	1.18	0.31	2.43	1.78	2.5	0.0	-14.0
13	$\text{CDCl}_3$	1.27	1.07	3.04 <sup>b</sup>	2.31 <sup>b</sup>	3.5 <sup>b</sup>	0.0 <sup>b</sup>	-14.5 <sup>b</sup>
	$\text{C}_6\text{H}_6$	1.11	0.59	2.62	1.87	3.3	0.0	-14.4
14	$\text{CDCl}_3$	1.28	1.04	2.97	2.24	2.9	0.0	-14.4
	$\text{C}_6\text{H}_6$	1.15	0.58	2.58	1.83	3.0	0.0	-14.0
15	$\text{CDCl}_3$	1.27	1.08	3.13	2.29	3.2	0.0	-14.0
	$\text{C}_6\text{H}_6$	1.08	0.58	2.88	1.88	3.2	0.0	-13.8
16	$\text{CDCl}_3$	1.32	1.16	3.44	2.53	4.7	0.5 <sup>c</sup>	-14.0
	$\text{C}_6\text{H}_6$	0.96	0.51	3.06	1.87	4.8	$\sim 0.5^c$	-14.1
17 <sup>d</sup>	$\text{CDCl}_3^e$	1.15	1.12			$J_{\text{Pa}} + J_{\text{Pb}} \cong 16.5$		
	$\text{C}_6\text{H}_6$	0.94	0.69	2.72	2.38	$\sim 1$	$\sim 14$	-13.8

<sup>a</sup> Chemical shifts are in parts per million downfield from  $\text{Me}_4\text{Si}$ ; coupling constants are in hertz. <sup>b</sup> These parameters were used as input for the LAOCOON 3 NMR program. The computed AB spectrum agreed with the experimental spectrum without iteration. <sup>c</sup> Possibly negative in sign (see text). <sup>d</sup> In  $\text{Cl}_2\text{CCl}_2$  at  $-85^\circ\text{C}$ :  $\delta$   $\text{CH}_2$ (b) is 2.65,  $\delta$   $\text{CH}_2$ (a) is 2.98;  $J_{\text{Pa}} = 1$  Hz,  $J_{\text{Pb}} = 14$  Hz,  $J_{\text{ab}} = -14$  Hz. <sup>e</sup> The assignment of axial and equatorial positions is tentative.

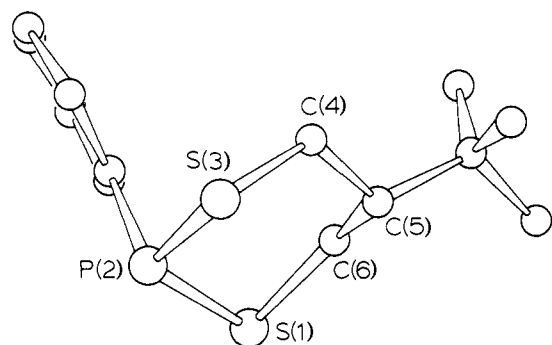
Figure 1. Structure and solid-state conformation of **7a**.

cancellation of PSCCH couplings possessing opposite signs in individual conformers (see Chlorine-Exchange subsection). Also, it is noteworthy that  $|^4J_{\text{PSCCH}}|$  is greater than  $|^3J_{\text{PSCCH}}|$ , which contradicts the often recorded observation that the magnitude for coupling between nuclei is attenuated across an increasing number of bonds, i.e.,  $|^1J| > |^2J|$ ;  $|^3J| > |^4J|$ .<sup>23</sup>

Definitive information on the configuration at phosphorus in **7a–9a** is provided by the  $^1\text{H}$  NMR data (Table I). A hint of the orientation of P substituents rests with the difference in chemical shifts between  $\text{H}_a$  and  $\text{H}_b$  ( $\Delta_{\text{ab}} = \delta_a - \delta_b$ ). In **8a** and **9a** the axial protons ( $\text{H}_a$ ) resonate at a lower field than the equatorial protons ( $\text{H}_b$ ), the same relative order that has been recorded for the  $\text{C}_{4,6}$  protons in 1,3,2-dioxo-<sup>24</sup> and 1,3,2-diazaphosphorinanes.<sup>19</sup> A reversal of this normal order is observed for **7a**, which is similar to the order reversal reported for **10**.<sup>13,25</sup> The shielding of the axial 4,6 protons is attributable to the effect of the aromatic ring current on a proximate, axial P-phenyl group. The  $^4J_{\text{Kx}}$  value for **7a** of 3 Hz is consistent with this assignment, for an equatorial P substituent would be expected to produce a  $^4J_{\text{Kx}}$  of  $\sim 8$  Hz.<sup>20</sup> Also, the  $^3J_{\text{PH}}$  coupling constants are characteristic of an axial disposition for P substituents in **7a–9a** (vide infra).<sup>14,15</sup>

Single-crystal X-ray analysis of **7a** afforded the first determination of molecular structure for a tricoordinate 1,3,2-dithiaphosphorinane (Figure 1).<sup>16b,26</sup> A chair conformation is adopted

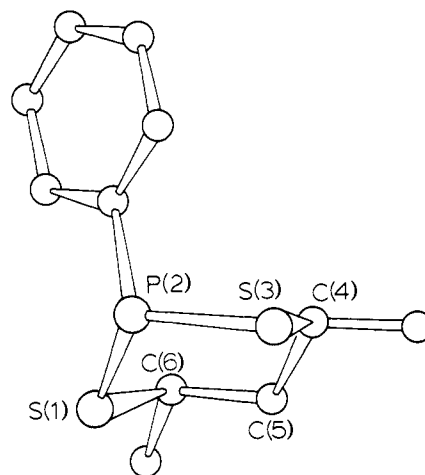
Figure 2. Structure and solid-state conformation of **11b**.

in the solid state and **7a** possesses cis stereochemistry (axial phenyl and equatorial *tert*-butyl groups), as suggested by  $^1\text{H}$  NMR data.

The synthesis of **11** (lp = lone pair of electrons), a system with conformationally biasing *cis*-4,6-dimethyl groups, produced a 40:60 mixture of diastereomers **11b** and **11a**, respectively. The isomers in the mixture were distinguished in the  $^1\text{H}$  NMR spectrum (100 MHz) by the methyl resonances ( $\text{CDCl}_3$  or  $\text{C}_6\text{D}_6$ ) and by the separate multiplets for the 4,6 protons ( $\text{C}_6\text{D}_6$ ), integration of which gave the isomeric composition [ $\delta$  ( $\text{C}_6\text{D}_6$ ) **11b**: 0.93 (dd,  $^3J_{\text{HH}} = 7$  Hz,  $^4J_{\text{PH}} = 1.2$  Hz,  $\text{CH}_3$ ), 2.35–2.7 (m, centered at  $\delta$  2.54); **11a**: 1.18 (dd,  $^3J_{\text{HH}} = 7$  Hz,  $^4J_{\text{PH}} = 1.2$  Hz,  $\text{CH}_3$ ), 2.7–3.05 (m, centered at  $\delta$  2.88)].

The more stable diastereomer **11b** was obtained isomerically pure. Its 250-MHz  $^1\text{H}$  NMR spectrum in  $\text{C}_6\text{D}_6$  revealed an  $\text{ABK}_2\text{T}_6\text{X}$  pattern (X =  $^{31}\text{P}$ ; T = methyl):  $\delta$  0.94 (dd, 6,  $\text{CH}_3$ ), 1.15 (d of d of t, 1,  $^2J_{\text{ab}} = 14.4$  Hz,  $^3J_{\text{bk}} = 2.2$  Hz,  $^4J_{\text{bx}} = 10.0$  Hz;  $\text{H}_b$ ), 1.33 (d of d of t, 1,  $^3J_{\text{ak}} = 11.2$  Hz,  $^4J_{\text{ax}} = 3.4$  Hz,  $^2J_{\text{ab}}$ ;  $\text{H}_a$ ), 2.55 (d of d of q, 2,  $^3J_{\text{kt}} = 7.0$  Hz,  $^3J_{\text{kx}} = \sim 0$  Hz,  $^3J_{\text{ak}}$ ,  $^3J_{\text{bk}}$ ;  $\text{H}_k$ ). It is interesting to note the large four-bond  $^{31}\text{P}$ -H coupling values of 3.4 Hz for the axial  $\text{C}_5$  proton and 10.0 Hz for the equatorial  $\text{C}_5$  proton, which characterize 1,3,2-dithiaphosphorinanes with axial P substituents.<sup>15,20</sup>

The 250-MHz  $^1\text{H}$  NMR spectrum of a mixture of **11a** and **11b** (60:40) afforded some spectral parameters for the less stable diastereomer **11a** by analysis of the multiplets for  $\text{H}_b$  at  $\delta$  1.35–1.65 (centered at  $\delta$  1.45) and  $\text{H}_k$  at  $\delta$  2.75–2.95 (centered at  $\delta$  2.83) [ $\text{H}_a$  was concealed ( $\delta$  1.0–1.3)]. Thus,  $^3J_{\text{ak}} = 11.0$  Hz,  $^3J_{\text{bk}} = 2.0$  Hz,  $^3J_{\text{kt}} = 6.8$  Hz,  $^3J_{\text{kx}} = 1.8$  Hz,  $^4J_{\text{bx}} = 2.0$  Hz, and  $J_{\text{ab}} = 14.4$  Hz ( $^4J_{\text{ax}}$  could not be determined). The relative order of chemical shifts for  $\text{H}_a$  and  $\text{H}_b$  is opposite in **11a** and **11b**, reflecting the influence of orientation of the 2-phenyl group. This property was recorded by Robert's group,<sup>15</sup> but their examples involved compounds with different kinds of 2-substituents. The three-bond

(23) Jackman, L. M.; Sternhell, S., "Applications of NMR Spectroscopy in Organic Chemistry," 2nd ed, Pergamon Press, London, 1969.

(24) (a) White, D. W.; McEwen, G. K.; Bertrand, R. D.; Verkade, J. G., *J. Magn. Reson.*, **4**, 123 (1971); (b) White, D. W.; Bertrand, R. D.; McEwen, G. K.; Verkade, J. G., *J. Am. Chem. Soc.*, **92**, 7125 (1970); (c) Bentrude, W. G.; Hargis, J. H., *J. Am. Chem. Soc.*, **92**, 7136 (1970); (d) Haemers, M.; Ottinger, R.; Reisse, J.; Zimmerman, D., *Tetrahedron Lett.*, 461 (1971); (e) Bergesen, K.; Albriktsen, P., *Acta Chem. Scand.*, **25**, 2257 (1971).

(25) Bentrude, W. G.; Yee, K. C., *Tetrahedron Lett.*, 3999 (1970).

(26) Details of the single-crystal X-ray diffraction analyses will appear in a separate paper.<sup>17</sup> Herein, we present a single view of the solid-state conformation for each compound studied (Figures 1, 2, 5–13). Also, a table of endocyclic torsion angles is furnished in the supplementary materials. It should be noted that detailed diffraction data for three compounds, **5**, **6**, and **7a**, are already available in our preliminary communication.<sup>16b</sup>



Table III. Equilibrium Data for Thermal Equilibration of 7

$T, ^\circ\text{C}$	$K$	$\Delta G(\text{exptl})^a$	$\Delta G(\text{calcd})^a$
150	7.3	-1.68	-1.69
175	6.5	-1.67	-1.64
200	$5.4 \pm 0.2^b$	-1.59	-1.60
225	4.8	-1.55	-1.56

<sup>a</sup> Given in kcal/mol. <sup>b</sup> Average of three experiments.

tution, which is expected to impose a stronger biasing effect than 5-*tert*-butyl substitution,<sup>18</sup> was also explored.

Reaction of 2-*tert*-butyl-1,3-propanedithiol with phenyldichlorophosphine afforded a mixture (ca. 85:15) of *cis* and *trans* isomers, **7a** and **7b**, which were inseparable by TLC and GLC. The two isomers in the mixture were differentiated by the *tert*-butyl singlets in the <sup>1</sup>H NMR spectrum of the mixture [ $\delta$  (CDCl<sub>3</sub>): **7a**, 0.76; **7b**, 0.99]<sup>30</sup> and quantitated by integration. The major isomer, **7a**, was easily separated by fraction crystallization from methanol, but attempts to isolate the minor component, **7b**, have been fruitless. The major isomer, **7a**, was found to be the thermodynamically more stable one by thermal equilibration (eq 3)

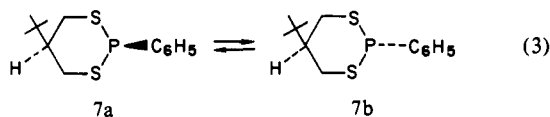

monitored by <sup>1</sup>H NMR. At 200 °C equilibrium (from pure **7a**) was attained in ~7 h, giving a final ratio (**7a**/**7b**) of 84.5:15.5. Thermal equilibration of **7a**, under conditions where acid was punctiliously eliminated, was complete in ~20 h at 200 °C, giving the same final isomer ratio. Acceleration of the thermal stereomutation process by traces of acid is not unusual since acid-catalyzed equilibration of 1,3,2-dioxaphosphorinanes has been documented.<sup>24c,31</sup>

An equilibrium mixture of **7a** and **7b** produced at 210 °C was oxidized stereospecifically (vide infra) with 3% aqueous H<sub>2</sub>O<sub>2</sub> to a mixture of epimeric oxides **5** and **6**, each of which had already been independently prepared and characterized (vide infra). TLC and GLC distinguished the two oxides, and GLC analysis gave an isomer ratio (**6**/**5**) of ca. 85:15 (which agreed with <sup>1</sup>H NMR integration). This confirms that the minor substance in the two-component mixture from the heating of **7a** is, indeed, **7b**.

Equilibrium data, obtained at different temperatures, are compiled in Table III. A plot of ln  $K$  vs.  $1/T$  and a least-squares fit of the data give the enthalpy and entropy differences that define the free-energy change at 25 °C, i.e.,  $\Delta G^\circ_{25} = 1.91 \pm 0.2$  kcal/mol. Calculated values for  $\Delta G$  appear in Table III. The equilibrium was temperature dependent, but the data are not precise enough to allow a reliable determination of the entropy difference. The computed fit affords:  $\Delta H^\circ = -2.4 \pm 0.3$  kcal/mol and  $\Delta S^\circ = 1.8 \pm 0.7$  eu.

Kinetics were measured under acid-free conditions at 175, 200, and 225 °C (see Figure 4). An effective rate constant ( $K_{\text{eff}}$ ) was determined at each temperature by a least-squares fit of the rate data for the first 3 half-lives. Using the Eyring equation, assuming a value of 1.0 for the transmission coefficient, we calculated the  $\Delta G^\ddagger$  values for the three temperatures. A least-squares fit of  $\Delta G^\ddagger = \Delta H^\ddagger - T\Delta S^\ddagger$  furnished  $\Delta G^\ddagger_{25} = 31.4$  kcal/mol for the barrier to pyramidal inversion at phosphorus in **7a**. The pyramidal inversion barrier for an analogous phosphine bearing two sulfur atoms and a phenyl group, bis(isopropylthio)phenylphosphine, was reported to be 24.5 kcal/mol (from DNMR measurements).<sup>32,33</sup>

(30) <sup>13</sup>C NMR was also suitable for differentiation of **7a** and **7b** (see subsection on <sup>13</sup>C and <sup>31</sup>P NMR).

(31) (a) Aksnes, G.; Eriksen, R.; Melligen, K., *Acta Chem. Scand.*, **21** 1028 (1967); (b) Bodkin, C. L.; Simpson, P., *J. Chem. Soc. B*, 1136 (1971).

(32) Rauk, A.; Andose, J. D.; Frick, W. G.; Tang, R.; Mislow, K., *J. Am. Chem. Soc.*, **93**, 6507 (1971).

(33) Repetition of this measurement under scrupulously acid-free conditions afforded the same value.

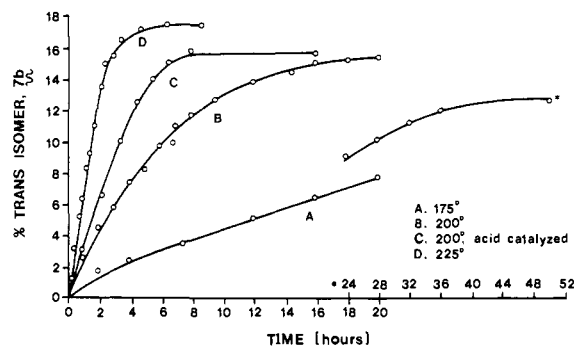

Figure 4. Equilibration of *r*-2-phenyl-*c*-5-*tert*-butyl-1,3,2-dithiaphosphorinane (**7a**).

The higher  $\Delta G^\ddagger$  for **7a** than for the acyclic phosphine relates to the ability of a six-membered ring to elevate the barrier to inversion of phosphorus.<sup>34</sup>

Reaction of *meso*-2,4-pentanedithiol with phenyldichlorophosphine gave a mixture (ca. 40:60) of isomers **11b** and **11a**. The two isomers in the mixture were distinguished and quantitated as described above.<sup>35</sup> Isomers **11a** and **11b** were separable by GLC, but GLC was unsuitable for accurate quantitation because of thermal equilibration that occurred during analysis. Enriched samples of **11a** and **11b** were initially obtained by preparative GLC; a pure sample of **11b** was also obtained by fractional crystallization. Since thermal equilibration of **11** by the method used for **7** was complicated by considerable decomposition, a thorough study could not be conducted. Equilibrium was attained in the gas chromatograph on degenerated columns at 170 °C, or in a sealed tube on a neat sample at 130 °C. A 91:9 GLC ratio of **11b** and **11a** was consistently reproducible. An ca. 95:5 ratio of **11b**/**11a** was observed in the sealed-tube, thermal equilibration. The GLC equilibrium ratio for **11b**/**11a** ( $K = 10.1$ ) leads to a  $\Delta G_{170}$  value of  $-2.05$  kcal/mol, and the other ratio ( $K = \sim 19$ ) gives  $\Delta G_{130} = \sim -2.3$  kcal/mol. These  $\Delta G$  values afford a good approximation of the free-energy difference ( $-\Delta G = 2.0$ – $2.3$  kcal/mol) between an axial and equatorial *P*-phenyl substituent since the *cis*-4,6-dimethyl groups provide a very effective conformational bias. The  $\Delta G_{175}$  value of  $\sim -1.7$  kcal/mol for **7** is consistent with this result; the diminished value is probably a consequence of less effective biasing by the 5-*tert*-butyl group.

**Chlorine-Exchange Reaction in Chlorophosphines 16 and 18d.** The <sup>1</sup>H NMR spectra of **16** in C<sub>6</sub>H<sub>6</sub> and CDCl<sub>3</sub> are described in Table II. In these spectra no chlorine exchange was evident at the 5–10% (w/v) concentrations employed, or even on addition of D<sub>2</sub>O, CF<sub>3</sub>CO<sub>2</sub>H, or 90% formic acid. However, addition of a small amount of tetraethylammonium chloride to a solution of **16** in CDCl<sub>3</sub> immediately caused collapse of the pair of C<sub>5</sub> methyl singlets into a single, sharp singlet at  $\delta$  1.23 and of the complex methylene pattern into a broadened singlet at  $\delta$  2.95. In CD<sub>3</sub>NO<sub>2</sub> partial exchange occurred without addition of any catalysts. Thus, the C<sub>5</sub> methyls appeared as a broadened singlet at  $\delta$  1.22 and the methylene groups gave a pair of broad signals. Addition of a small amount of tetraethylammonium chloride to the CD<sub>3</sub>NO<sub>2</sub> sample caused collapse of the methylene signals into a broadened singlet at  $\delta$  2.97 and sharpening of the C<sub>5</sub>-methyl singlet. Careful addition of small increments of the ammonium chloride to a solution of **16** in CDCl<sub>3</sub> illustrated that an increasing concentration of chloride causes an increasing rate of exchange.

(34) The barrier to pyramidal inversion of nitrogen in six-membered ring amines can be elevated compared to that in acyclic amines, albeit not nearly as much: see (a) Dewar, M. J. S.; Jennings, W. B., *J. Am. Chem. Soc.*, **93**, 401 (1971); (b) Bushweller, C. H.; O'Neil, J. W., *J. Am. Chem. Soc.*, **92**, 2159 (1970); (c) Katriisky, A. R.; Patel, R. C.; Riddell, F. G., *J. Chem. Soc., Chem. Commun.*, 674 (1979). The barrier in 1-phenyl-4-*tert*-butylphosphorinane (36.0 kcal/mol at 180 °C) is 4 kcal/mol higher than corresponding acyclic phosphines: see (d) Macdonell, G. D.; Berlin, K. D.; Baker, J. R.; Ealick, S. E.; van der Helm, D.; Marsi, K. L., *J. Am. Chem. Soc.*, **100**, 4535 (1978).

(35) <sup>31</sup>P and <sup>13</sup>C NMR were also suitable for differentiating **11a** and **11b** (see subsection on <sup>13</sup>C and <sup>31</sup>P NMR).

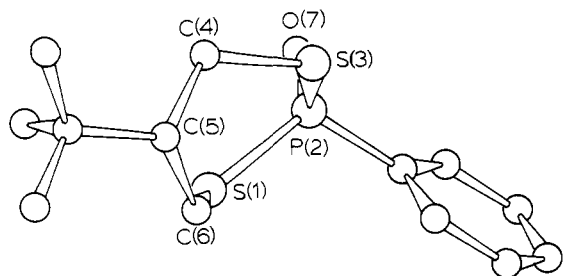

Figure 5. Structure and solid-state conformation of **5**.

The halogen-exchange process in halophosphines,<sup>36</sup> which effects stereomutation at pyramidal phosphorus, may be caused by trace impurities<sup>36a</sup> or small amounts of acid.<sup>19</sup> Chloride ion has been noted to greatly accelerate the exchange process.<sup>24b,37</sup> Experiments on **16** expose that acid or water are insufficient catalysts for exchange in the dithiaphosphorinane system, whereas chloride ion is very effective. Water may have no effect because of sluggish hydrolysis of **16** to form HCl.

The <sup>31</sup>P-H coupling is nearly unobservable in the fully change-averaged spectrum of **16**. The width at half-height of the methylene singlet is ~3 Hz compared to the width of ~1.2 Hz for the C<sub>3</sub>-methyl singlet, which yields an upper limit of ~2 Hz for <sup>3</sup>J<sub>PSC<sub>H</sub></sub>. Position averaging will give an averaged coupling according to  $J = (J_{ax} + J_{bx})/2$ , thus  $J_{ax} + J_{bx}$  must be equal to ~4 Hz. The coupling data for **16** (Table II) do not agree with this conclusion (4.7 + 0.5 = 5.2 Hz) unless one of the <sup>3</sup>J<sub>PSC<sub>H</sub></sub> values is negative in sign (4.7 - 0.5 or 0.5 - 4.7 = 4.2 Hz). Consequently, either the  $J_{ax}$  or (nonzero)  $J_{bx}$  values may be negative for all of the tricoordinate 1,3,2-dithiaphosphorinanes with axial *P* substituents. In this regard, the <sup>1</sup>H NMR spectrum of 2-fluoro-1,3,2-dithiaphosphorinane showed small <sup>3</sup>J<sub>PSC<sub>H</sub></sub> values of opposite sign,  $J = +1.7$  Hz and  $J = -0.7$  Hz (stereochemistry not assigned),<sup>38</sup> and the spectrum of 2-phenyl-1,3,2-dithiaphosphorinane showed small <sup>3</sup>J<sub>PSC<sub>H</sub></sub> values (<2 Hz) of opposite sign.<sup>39,40a</sup>

The <sup>1</sup>H NMR spectrum of **18d** will theoretically display an AA'BB'QTX ( $X = ^{31}\text{P}$ ) pattern. With the usually negligible cross-ring coupling, an A<sub>2</sub>B<sub>2</sub>QTX approximation may be considered. The spectrum for **18d** (C<sub>6</sub>H<sub>6</sub>), which was thoroughly analyzed by Robert's group during the course of our work,<sup>15a</sup> exhibits multiplets in three regions centered at δ 3.4 (H<sub>a</sub>), 2.02 (H<sub>b</sub>), and 1.4 (H<sub>q</sub>, H<sub>t</sub>). The multiplet corresponding to H<sub>a</sub> resembles a triplet of triplets, the integrated ratio (6:17:11; low-to-high field) of which suggests one-half of an AB quartet with overlap in the middle caused by the existence of two large couplings ( $J_{ab}$  and  $J_{aq}$ ) approximately equal in magnitude (not necessarily in sign). Two smaller couplings afford the triplet substructure. Analysis of the spectrum gives the following estimated coupling constants:  $J_{ab} \approx 13.5$  Hz,  $J_{aq} \approx 12.5$  Hz,  $J_{at} \approx 3$  Hz,  $J_{ax} \approx 3.5$  Hz.<sup>40b</sup> The multiplet, at higher field, for H<sub>b</sub> appears as two broad signals, the center of each being separated by about 14 Hz ( $J_{ab}$ ); the substructure of the multiplet was difficult to analyze by direct observation of the NMR spectrum.

In CD<sub>3</sub>NO<sub>2</sub> the <sup>1</sup>H NMR spectrum of **18d** consists of three, more closely spaced multiplets centered at δ 3.65 (H<sub>a</sub>), 2.92 (H<sub>b</sub>), and 2.3 (H<sub>q</sub> and H<sub>t</sub>). Addition of a small amount of tetraethylammonium chloride induced chlorine exchange. The collapsed AB resonance was partially obscured by the CH<sub>2</sub>N<sup>+</sup> signal of the ammonium salt, but the QT resonance at higher field was observed to undergo a complex transformation on incremental

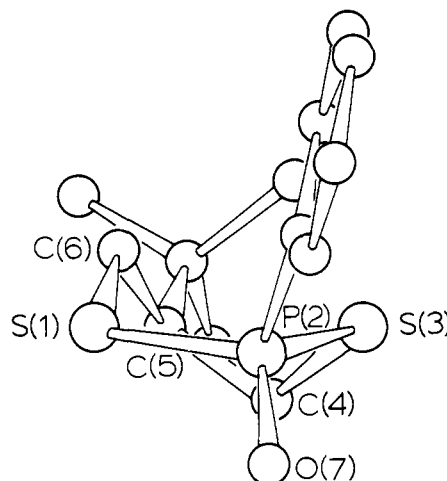
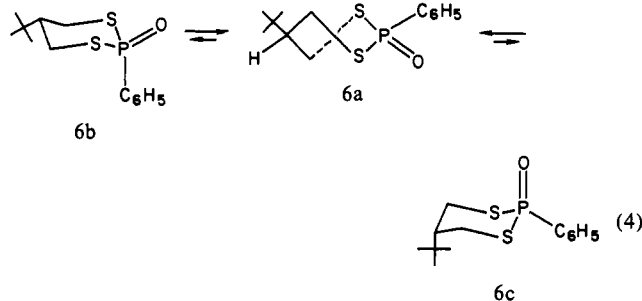

Figure 6. Structure and solid-state conformation of **6**.

additions of chloride ion, due to an increasing rate of exchange, until it assumed the appearance of a pentet (splitting = 7 Hz), reflecting interaction with the four magnetically equivalent 4,6 protons.

<sup>1</sup>H NMR Spectra and Stereochemistry of Tetracoordinate Compounds. Since the tricoordinate 1,3,2-dithiaphosphorinanes displayed interesting conformational properties, namely the axial preference of substituents on phosphorus,<sup>11</sup> we also investigated derivatives containing tetracoordinate phosphorus. A complete stereochemical analysis and an X-ray analysis (Figures 5 and 6) of *c*-5- and *t*-5-*tert*-butyl-*r*-2-oxo-2-phenyl-1,3,2-dithiaphosphorinanes (**5** and **6**, respectively) have already been published by us.<sup>16</sup> The hallmark of these studies is the propensity of the 2-oxo-1,3,2-dithiaphosphorinanes to assume a twist conformation, which is favored in solution by **6** and adopted in the solid state by both **5** and **6** (Figures 5 and 6).<sup>41</sup> We have since performed variable-temperature <sup>1</sup>H NMR studies on **6** in 1,1,2,2-tetrachloroethane-*d*<sub>2</sub> from -20 to 120 °C and in 1,2-dichlorobenzene from 0 to 150 °C. The absence of any changes in the <sup>1</sup>H NMR coupling parameters over these temperature ranges indicates the nonexistence of a shifting conformational equilibrium. Thus, **6** exists predominantly in a twist conformation (**6a**) with chair conformers (**6b** and **6c**) contributing minimally to the overall conformational equilibrium (see eq 4). In this paper we present



our results on the 2-thiono analogues of **5** and **6** (**20b** and **20a**), 4,6-dimethyl-2-oxo compounds **22** and **23**, and a series of 5,5-dimethyl-2-oxo compounds **24-28**.

Condensation of 2-*tert*-butyl-1,3-propanedithiol with phenylthiophosphonic dichloride afforded a mixture of **20a** and **20b**. The isomers were separated and the lower melting one was identified as the *cis* isomer by comparison with a sample of **20a** from sulfurization of *cis* phosphine **7a**. The 90-MHz <sup>1</sup>H NMR spectrum (CDCl<sub>3</sub>) of *cis* isomer **20a** showed a singlet at δ 0.89 (*tert*-butyl), a triplet of triplets at δ 1.98 (H<sub>b</sub>), and a complex multiplet between δ 2.5 and 3.5 for H<sub>a</sub> and H<sub>t</sub>. Irradiation of the signal for H<sub>t</sub> caused a collapse of the complex multiplet with loss of  $J = 10$  Hz from

(41) In contradistinction, X-ray analysis of 2,*c*-5-di-*tert*-butyl-*r*-2-oxo-1,3,2-dithiaphosphorinane (**19**), an analogue of **5**, revealed a chair conformation with equatorial 2- and 5-*tert*-butyl groups (Figure 7).<sup>26</sup>

(36) (a) Cox, R. H.; Newton, H. G.; Campbell, B. S., *J. Am. Chem. Soc.*, **93**, 530 (1971); (b) Lockhart, J., *Chem. Rev.*, **64**, 147 (1964); (c) Bissey, J. E.; Goldwhite, H.; Rowsell, D. G., *Org. Magn. Reson.*, **2**, 81 (1970).

(37) Goldwhite, H.; Rowsell, D. G., *Chem. Commun.*, 1665 (1968).

(38) (a) Albrand, J. P.; Cogne, A.; Gagnaire, D.; Martin, J.; Robert, J. B.; Verrier, J., *Org. Magn. Reson.*, **3**, 75 (1971); (b) Albrand, J. P.; Gagnaire, D.; Martin, J.; Robert, J. B., *Org. Magn. Reson.*, **5**, 33 (1973).

(39) Peake, S. C.; Fild, M.; Schmutzler, R.; Harris, R. K.; Nichols, J. M.; Rees, R. G., *J. Chem. Soc., Perkin Trans. 2*, 380 (1972).

(40) (a) Quin and Littlefield<sup>27b</sup> have briefly discussed changes of sign for three-bond <sup>31</sup>P-<sup>13</sup>C couplings in phosphine derivatives. (b) Martin et al.<sup>15a</sup> reported couplings of 14.0, 12.5, 2.2, and 4.2 Hz, respectively, for **18d**.

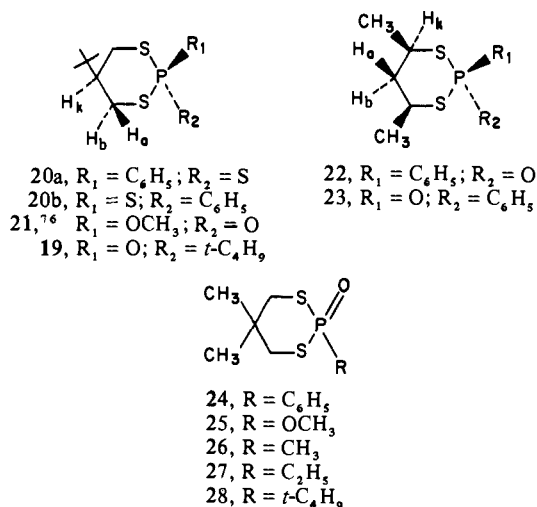

the upfield half ( $J_{ak}$ ) and  $J = 4$  Hz from the downfield ( $J_{bk}$ ). The simplified pattern furnished the other coupling constants:  $J_{ab} = 14$  Hz,  $J_{pb} = 24$  Hz, and  $J_{pa} = 11$  Hz. The 90-MHz <sup>1</sup>H NMR spectrum (CDCl<sub>3</sub>) of *trans* isomer **20b** showed a singlet at  $\delta$  1.03 (*tert*-butyl), a triplet of triplets at  $\delta$  1.94 (H<sub>k</sub>), and a complex multiplet between  $\delta$  3.0 and 3.8 (H<sub>a</sub> and H<sub>b</sub>). Irradiation of H<sub>5</sub> simplified the pattern for H<sub>a</sub> and H<sub>b</sub>, leading to an assignment of coupling constants:  $J_{ak} = 10.5$  Hz,  $J_{bk} = 3$  Hz,  $J_{ab} = 14$  Hz,  $J_{pb} = 24$  Hz, and  $J_{pa} = 11$  Hz. These data indicate the predominance of a chair conformer with equatorial *tert*-butyl and axial 2-phenyl groups for **20a** and equatorial 2-phenyl and axial 2-phenyl groups for **20b**. In the spectrum of **20a** H<sub>a</sub> is upfield of H<sub>b</sub>, but in the spectrum of **20b** H<sub>a</sub> is downfield of H<sub>b</sub>. This reversal in relative order of chemical shifts is an anticipated characteristic of the assigned chair conformers (vide supra; see ref 13, 14, 16a, and 25). Thus, whereas *cis*-2-oxo derivative **6** largely adopts a twist conformation in CDCl<sub>3</sub> solution, its *cis*-2-thiono analogue **20a** does not!

A single-crystal X-ray diffraction study on **20a** corroborated the stereochemical assignment and depicted the same conformation as observed in solution (Figure 8).<sup>26</sup>

Condensation of phenylphosphonic dichloride with *meso*-2,4-pentanedithiol furnished a mixture of **22** and **23**. The isomers were separated and identified on the basis of a sample of **23** obtained by stereospecific oxidation of **11b**. The 90-MHz <sup>1</sup>H NMR spectrum (CDCl<sub>3</sub>) of **22** showed a doublet of doublets at  $\delta$  1.45 (CH<sub>3</sub>) with  $J_{HH} = 7$  Hz and  $^4J_{PH} = 2.5$  Hz, a doublet of triplets at  $\delta \sim 1.75$  (H<sub>a</sub>) with  $J_{ab} = 14.5$  Hz and  $J_{ak} = 11.5$  Hz, a doublet of triplets at  $\delta \sim 2.28$  (H<sub>b</sub>) with  $J_{ab} = 14.5$  Hz and  $J_{bk} = 2$  Hz, and complex multiplet between  $\delta$  3.6 and 4.1 for H<sub>k</sub>. Double-irradiation experiments involving decoupling of the methyl groups simplified the complex multiplet into a doublet of doublets centered at  $\delta$  3.84 with  $J_{bk} = 2$  Hz,  $J_{pk} = 4.5$  Hz, and  $J_{ak} = 11$  Hz. Irradiation of the center of the complex multiplet ( $\delta$  3.9) caused the collapse of the CH<sub>3</sub> resonance and the resonances for H<sub>a</sub> and H<sub>b</sub> as expected. The 90-MHz <sup>1</sup>H NMR spectrum of **23** showed a doublet of doublets at  $\delta$  1.41 (CH<sub>3</sub>) with  $J_{HH} = 7$  Hz and  $^4J_{PH} = 3.0$  Hz, a doublet of triplets for H<sub>a</sub> at  $\delta \sim 1.68$  with  $J_{ab} = 14.5$  Hz and  $J_{ak} = 11$  Hz, a doublet of triplets for H<sub>b</sub> at  $\delta \sim 2.08$  with  $J_{ab} = 14.5$  Hz and  $J_{bk} = 2.5$  Hz, and a complex multiplet between  $\delta$  2.65 and 3.15. Irradiation of the methyl resonance simplified the complex multiplet to a doublet of doublets centered at  $\delta$  2.90 with  $J_{ak} = 11$  Hz,  $J_{pk} = 4.5$  Hz, and  $J_{bk} = 2.5$  Hz. Irradiation of the complex multiplet at  $\delta$  2.9 caused appropriate decoupling in the CH<sub>3</sub>, H<sub>a</sub>, and H<sub>b</sub> resonances.

The <sup>1</sup>H NMR coupling parameters clearly indicate that **22** and **23** each adopt a strongly biased chair conformation. There is no evidence for a contribution of a twist conformer to the conformational equilibrium for **23**. The 4,6 diequatorial methyl groups impose a strong bias on the conformational distribution, counteracting any tendency toward population of a twist form in **23**.

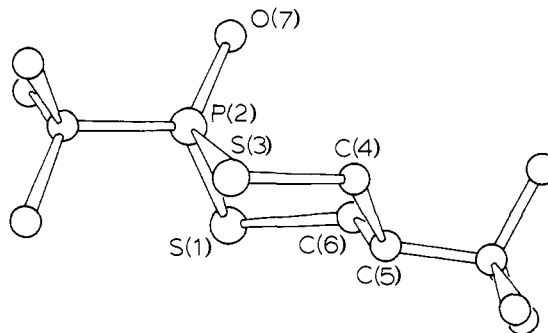

Figure 7. Structure and solid-state conformation of **19**.

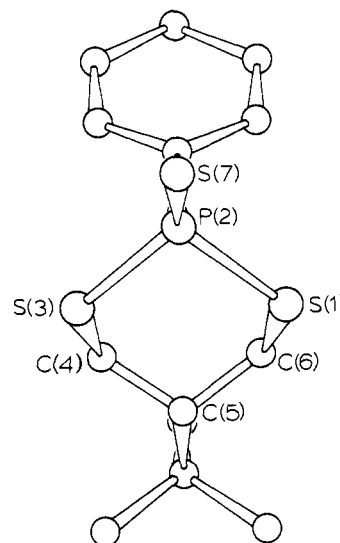

Figure 8. Structure and solid-state conformation of **20a**.

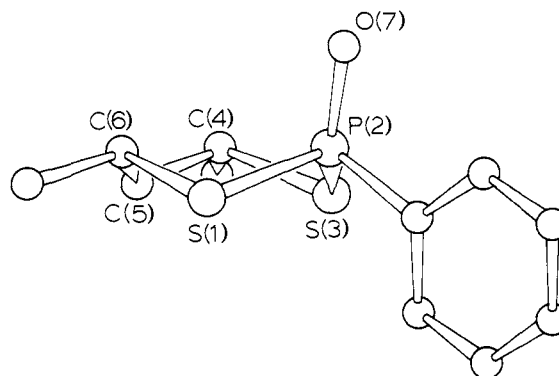

Figure 9. Structure and solid-state conformation of **22**.

X-ray diffraction studies were conducted on single crystals of both **22** and **23**. These diastereomers were found to adopt chair conformations in the solid state with diequatorial 4,6-methyl groups and an equatorial (22) or axial (23) *P*-phenyl group (Figures 9 and 10).<sup>26</sup>

For further exploration of the conformational properties of the 2-oxo-1,3,2-dithiaphosphorinane series, a group of 2-substituted derivatives unbiased by substitution at carbons 4, 5, and 6 were prepared and studied. The 5,5-dimethyl compounds (**24–28**) were chosen because of <sup>1</sup>H NMR spectral simplification offered by the geminal methyl groups. We hoped that the <sup>1</sup>H NMR spectral data would permit an estimation of conformer populations in relation to the substituent on phosphorus.

<sup>1</sup>H NMR data for **24–28** in CDCl<sub>3</sub> and C<sub>6</sub>D<sub>6</sub> are organized in Table IV. For **24–28**, the C<sub>5</sub> methyl groups were almost isochronous in CDCl<sub>3</sub>, but were well separated in C<sub>6</sub>D<sub>6</sub>. The spectra in C<sub>6</sub>D<sub>6</sub> allowed the assignment of the geminal methyl groups. The broader, shorter signal that appears at lower field



Table IV. <sup>1</sup>H NMR Data for 2-Oxo- and 2-Thiono-5,5-dimethyl-1,3,2-dithiaphosphorinanes<sup>a</sup>

compd	solvent	δ Me(ax)	δ Me(eq)	δ CH <sub>2</sub> (a)	δ CH <sub>2</sub> (b)	J <sub>ax</sub> <sup>b</sup>	J <sub>bx</sub> <sup>b</sup>	J <sub>ab</sub>
24	CDCl <sub>3</sub>	1.23 <sup>c</sup>	1.23 <sup>c</sup>	3.23	2.75	17.5	18.0	-14.5
	C <sub>6</sub> D <sub>6</sub>	0.85	0.66	3.00	2.21	15.5	18.7	-14.5
25	CDCl <sub>3</sub>	1.24	1.12	2.94	2.74	17.0	23.7	-14.5
	C <sub>6</sub> H <sub>6</sub>	0.82	0.54	2.51	2.18	16.5	24.3	-14.0
26	CDCl <sub>3</sub>	1.17 <sup>c</sup>	1.18 <sup>c</sup>	3.01	2.68	18.8	18.2	-14.8
	C <sub>6</sub> H <sub>6</sub>	0.73	0.62	2.76	2.05	17.6	17.9	-14.4
27	CDCl <sub>3</sub>	1.16 <sup>c</sup>	1.12 <sup>c</sup>	2.95	2.62	18.7	16.2	-14.3
	C <sub>6</sub> H <sub>6</sub>	0.73	0.68	2.68	2.09	17.3	15.5	-14.5
28	CDCl <sub>3</sub>	1.19 <sup>c</sup>	1.13 <sup>c</sup>	3.06	2.75	17.5	14.5	-14.2
	C <sub>6</sub> H <sub>6</sub>	0.73	0.63	2.76	2.19	15.5	14.5	-14.5
31a	CDCl <sub>3</sub>	1.21	1.27	3.23	2.80	16.0	19.5	-14.0
	C <sub>6</sub> D <sub>6</sub> <sup>d</sup>	0.77	0.72	3.01	2.25	14.7	20.2	
31b	C <sub>6</sub> D <sub>6</sub> <sup>d</sup>	0.68	0.65	2.77	2.13	16.5	19.0	

<sup>a</sup> Chemical shifts are in parts per million downfield from Me<sub>4</sub>Si; coupling constants are in hertz. Estimated error: ±0.3 Hz. <sup>b</sup> The relative order of the chemical shifts of H<sub>a</sub> and H<sub>b</sub> is presumed to be the same for every compound. The order is only known absolutely for 25. <sup>c</sup> The assignment of axial and equatorial positions is tentative. <sup>d</sup> From ref 44.

Table V. <sup>13</sup>C NMR Chemical Shift and <sup>31</sup>P-<sup>13</sup>C Coupling Constant Data<sup>a</sup>

compd	C <sub>4,6</sub> ( <sup>2</sup> J)	C <sub>5</sub> ( <sup>3</sup> J)	5-Mc[a, e] ( <sup>4</sup> J <sub>a</sub> , <sup>4</sup> J <sub>e</sub> )	5- <i>t</i> -Bu[α, β] ( <sup>4</sup> J)	2- <i>t</i> -Bu[α, β] ( <sup>1</sup> J, <sup>2</sup> J)	2-Ph[α, β, γ, δ] ( <sup>1</sup> J, <sup>2</sup> J, <sup>3</sup> J, <sup>4</sup> J)	4,6-Me ( <sup>3</sup> J)
A. Phosphines							
7a <sup>b</sup>	27.3 (13.9)	48.2 (1.0)		35.6, 27.5 (3.3)		137.3, 132.1, 129.2, 128.7 (41.8, 15.8, 3.1, 1.4)	
7b <sup>c,d</sup>	31.6 (8.5)	48.1 (11.5)		35.6, 28.4 (~3)			
11b	36.3 (9.8)	44.3 (~2.0)				137.8, 131.0, 128.7, 127.9 (41.0, 15.6, 2.9, <0.5)	24.5 (3.9)
11a <sup>d</sup>	41.4 (9.8)	45.2 (6.8)				134.3, 131.6, 128.6, 127.8 (30.0, 16.6, 1.8, <0.5)	24.3 (~0.5)
12	35.8 (11.7)	27.1 (0)	23.7, 32.8 (0, 3.9)			135.7, 131.4, 128.8, 128.3 (42.0, 16.6, 2.9, ~0.3)	
17	40.4 (8.8)	28.9 (4.9)	25.2, 29.2 (3.2, 0)		34.3, 27.4 (30.3, 16.1)		
18a <sup>e</sup>	24.1 (12.5)	25.8 (0)				<i>f</i> ( <i>f</i> )	
18b <sup>e</sup>	29.8 (9.1)	28.8 (8.4)			<i>f</i> ( <i>f</i> )		
B. Phosphine Oxides							
5 <sup>g</sup>	29.9 (3.3)	45.9 (1.5)		34.5, 27.3 (0.8)		133.3, 130.5, 128.5, 132.9 (111.5, 10.9, 14.3, 3.4)	
6	30.7 (3.9)	44.6 (2.9)		34.5, 27.5 (0)		135.5, 130.6, 128.5, 132.8 (113.3, 10.7, 13.7, 3.9)	
19	29.4 (2.9)	46.1 (0)		34.7, 27.7 (0)	40.3, 24.4 (70.3, 0)		
22	39.6 (2.0)	44.5 (2.0)				132.2, 130.9, 128.7, 133.3 (110.6, 11.2, 14.2, 3.2)	23.9 (10.7)
23	42.7 (4.0)	42.9 (3.9)				134.7, 130.6, 129.0, 132.8 (105.5, 12.2, 14.4, 3.4)	23.6 (10.8)
24	41.1 (3.2)	30.4 (2.2)	25.2, 27.1 (0.5, 0.5)			134.6, 130.5, 128.7, 133.0 (112.0, 11.0, 14.2, 3.2)	
28	40.3 (2.8)	31.2 (1.2)	25.4, 25.9 <sup>h</sup> (0.5, 0.5)		41.1, 24.2 (71.2, 0.4)		
C. Phosphine Sulfides							
20a	33.5 (3.9)	45.3 (2.4)		34.5, 27.4 (0)		136.0, 130.1, 129.1, 132.2 (82.8, 12.2, 14.4, 3.4)	
20b	31.7 (2.9)	47.5 (1.9)		34.7, 27.5 (0)		132.5, 131.4, 128.7, 133.2 (87.9, 11.7, 13.7, 3.9)	
30a <sup>i</sup>	30.5 (3.0)	26.1 (4.6)				<i>f</i> ( <i>f</i> )	
30d <sup>i</sup>	29.2 (2.8)	27.1 (3.0)			40.7 (50.2, 1.8)		
31a	42.7 (2.9)	28.8 (2.9)	25.8, 27.3 (0.5, 0.5)			133.9, 130.6, 128.8, 132.7 (85.9, 12.7, 14.6, 3.9)	

<sup>a</sup> Determined in CDCl<sub>3</sub>, unless otherwise noted. Chemical shifts are in parts per million downfield from Me<sub>4</sub>Si; coupling constants are in hertz. When more than one <sup>13</sup>C nucleus is handled in a single column, the assignments are signified in brackets (in the column headings). <sup>b</sup> Recorded on a Varian XL-100 instrument (Princeton University) at 25.2 MHz. <sup>c</sup> In 1,2,4-trichlorobenzene; thus, aromatic carbons were concealed. Parameters for the aliphatic carbons of 7a in this solvent were the same as in CDCl<sub>3</sub>. <sup>d</sup> Spectra were recorded on a mixture (unequal amounts) of this compound and its diastereomer. <sup>e</sup> Taken from ref 15a. <sup>f</sup> Not reported in the literature. <sup>g</sup> Recorded on a JEOL FX100Q instrument (JEOL Ltd. Applications Lab) at 25 MHz. <sup>h</sup> Assignments may be interchanged. <sup>i</sup> Taken from ref 44.



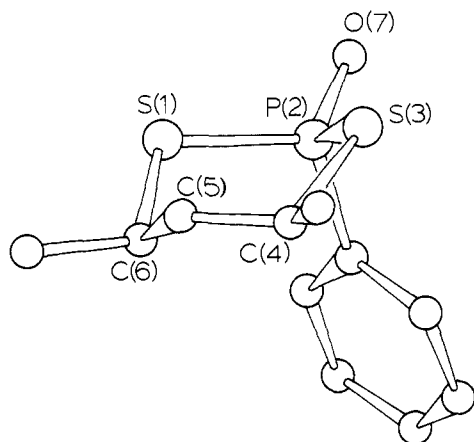

Figure 10. Structure and solid-state conformation of **23**.

was assigned to the axial methyl group (width at half-height is greater because of long-range coupling via a "W" pathway). Assignment of the methyl groups in the  $\text{CDCl}_3$  spectra could only be made for **25**, since it lacked the near identical chemical shifts seen with **24** and **26–28**.

A double-irradiation experiment on **25** in  $\text{C}_6\text{D}_6$  provided the assignment of the 4,6 protons. The broadened 5-methyl group was found to couple with the 4,6 protons at lower field; hence, these are the axial 4,6 protons. The methylene protons are part of AA'BB'K<sub>3</sub>X system (X =  $^{31}\text{P}$ ), which may be viewed as an A<sub>2</sub>B<sub>2</sub>X approximation for extraction of the two vicinal PSCH coupling constants directly from the experimental spectra. The three-bond  $^{31}\text{P}\text{--H}$  coupling constants ( $^3J_{\text{PSCH}}$ ),<sup>42</sup> which display a dependence on solvent and P substituent, are presented in Table IV. The variability of the  $^3J_{\text{PSCH}}$  values is indicative of changes in conformational distribution.

The conformational equilibrium for **24–28** may be comprised of two chair conformers and a twist conformer. With regard to the two chair forms, it is necessary to address the conformational preference of the substituents on phosphorus. Also, given the predominance of a twist conformation for **6**, one must consider a twist form as a potential contributor to the conformational profile for **24–28**.

The  $^3J_{\text{PSCH}}$  data can provide a handle for analysis of the conformational equilibria. First, extremes for  $^3J_{\text{PSCH}}$  have to be established. In 2-phenyl-2-oxo chair compounds, **22** and **23**, the limit for  $^3J_{\text{PSCH(ax)}}$  is 4.5 Hz for an equatorial phenyl or an axial phenyl substituent (the limits for  $^3J_{\text{HH}}$  are 11–11.5 and 2–2.5 Hz). The 2-phenoxy-2-oxo compound **29**, which exists almost completely

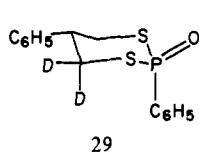

29

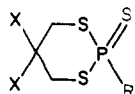

- 30a, R =  $\text{C}_6\text{H}_5$ ; X = H  
 b, R =  $\text{OCH}_3$ ; X = H  
 c, R =  $\text{CH}_3$ ; X = H  
 d, R = *t*- $\text{C}_4\text{H}_9$ ; X = H  
 e, R = Cl; X = H  
 f, R = (*i*- $\text{C}_3\text{H}_7$ )<sub>2</sub>N; X = H  
 g, R = 1-aziridinyl; X = H  
 31, R =  $\text{C}_6\text{H}_5$ ; X =  $\text{CH}_3$   
 32, R =  $\text{CH}_3$ ; X =  $\text{CH}_3$

in the chair conformer shown ( $^3J_{\text{HH}}$  in  $\text{CDCl}_3$  are 10.8 and 2.9 Hz), affords extreme values of  $^3J_{\text{PSCH(ax)}}$  of 9 Hz and  $^3J_{\text{PSCH(eq)}}$  of 28 Hz.<sup>43</sup> 2-Phenyl-2-oxo compound **5** largely exists in a chair conformation with equatorial 2-phenyl and 5-*tert*-butyl groups. Since the  $^3J_{\text{HH}}$  values of 9.5 and 3.5 Hz depart slightly from the extremes of  $\sim 11$  and  $\sim 3$  Hz, the presence of a small amount ( $\sim 15\%$ ) of another conformation is suggested; this is reflected

(42) These coupling constants have been assumed to be positive.

(43) Campbell, J. R.; Hall, L. D., *Chem. Ind.*, 1138 (1971). The epimer of **29** (not shown) exists, in solution, as a mixture of conformers ( $^3J_{\text{HH(ax)}} = 8.0$  and  $^3J_{\text{HH(eq)}} = 4.6$  Hz);  $^3J_{\text{PSCH(eq)}} = 24.5$  and  $^3J_{\text{PSCH(ax)}} = 18$  Hz).

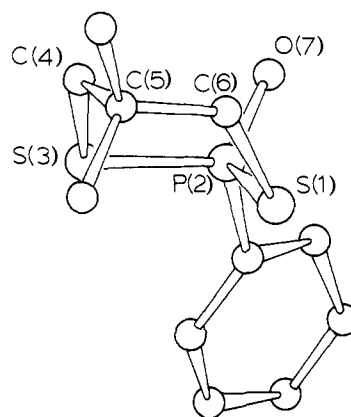

Figure 11. Structure and solid-state conformation of **24**.

in ostensible nonextreme values of  $^3J_{\text{PSCH(ax)}}$  (12 Hz) and  $^3J_{\text{PSCH(eq)}}$  (20 Hz). The near equivalency of  $^3J_{\text{PSCH(ax)}}$  and  $^3J_{\text{PSCH(eq)}}$  for **24** and **26–28** indicates that these molecules are a mixture of conformers with conformational equilibria in the vicinity of an average position. Interestingly, the R substituent on phosphorus in **24**, **26**, **27**, and **28** exerts only a weak influence on the  $^3J_{\text{PSCH}}$  values and thus on the conformational equilibria. The lack of a significant shift in conformer distribution for medium (methyl) vs. large (*tert*-butyl) groups in an equilibrium near its midpoint is peculiar. However, this observation may be reconciled by consideration of a substantial contribution from a twist form in the conformational equilibrium. Methoxy compound **25** appears to be a conformational mixture composed of a substantial proportion of the chair conformer with an axial methoxy group.

During the course of our work, a report on 2-thiono-1,3,2-dithiaphosphorinanes, unbiased by substitution at C<sub>4</sub>, C<sub>5</sub>, and C<sub>6</sub>, was published by Martin and Robert.<sup>44</sup> The 2-*tert*-butyl and 2-methoxy compounds (**30b** and **30d**) adopt (in  $\text{CCl}_4$ ) almost exclusively a chair conformation with an equatorial and axial 2-substituent, respectively ( $^3J_{4a5a} = 12.0$  and 12.5 Hz;  $^3J_{\text{PSCH(4a)}} = 9.2$  and 6.5 Hz;  $^3J_{\text{PSCH(4e)}} = 21.5$  and 25.5 Hz). The 2-phenyl and 2-methyl compounds (**30a** and **30c**) exhibit (in  $\text{CCl}_4$ ) a conformational equilibrium between two chair forms with a strong predominance of the P-equatorial conformer ( $^3J_{4a5a} = 11.0$  and 11.0 Hz;  $^3J_{\text{PSCH(4a)}} = 11.5$  and 12.5 Hz;  $^3J_{\text{PSCH(4e)}} = 20.5$  and 21.0 Hz). The 5,5-dimethyl analogues of **30a** and **30c** (i.e., **31** and **32**) were found to exhibit solvent-dependent conformational changes as evidenced by  $^3J_{\text{PSCH}}$  values [**31**:  $^3J_{\text{PH(ax)}}$ ;  $^3J_{\text{PH(eq)}} = 14.6$ ; 19.5 ( $\text{CCl}_4$ ), 14.7; 20.2 ( $\text{C}_6\text{D}_6$ ), 15.8; 18.6 ( $\text{CD}_3\text{CN}$ ), 17.0; 17.8 ( $\text{CH}_2\text{Cl}_2$ ) Hz and **32**:  $^3J_{\text{PH(ax)}}$ ;  $^3J_{\text{PH(eq)}} = 15.0$ ; 20.5 ( $\text{CCl}_4$ ), 16.5; 19.0 ( $\text{C}_6\text{D}_6$ ), 13.0; 21.0 ( $\text{CD}_3\text{CN}$ ), 17.0; 17.8 ( $\text{CH}_2\text{Cl}_2$ ) Hz].

The  $^3J_{\text{PSCH}}$  values for **31** and **32** in  $\text{CH}_2\text{Cl}_2$  are analogous to the values we observed for **24** and **26**, respectively, in  $\text{CDCl}_3$  (17.5; 18.0 and 18.8; 18.2), but the values for **31** and **32** in  $\text{C}_6\text{D}_6$  are less related to our values for **24** and **26** in  $\text{C}_6\text{D}_6$  (15.5; 18.7 Hz and 17.6; 17.9 Hz). In both the 2-thiono and 2-oxo 5,5-dimethyl compounds (**31** and **32**; **24** and **26**) a conformational equilibrium is indicated. The 2-thiono equilibrium is significantly shifted to a chair conformation with an equatorial 2-substituent, whereas the 2-oxo equilibrium is comprised of a mixture of nearly equal amounts of two chair conformers, possibly accompanied by a significant amount of twist conformer.

X-ray crystallographic studies were performed on **24** and **28**.<sup>26</sup> Compound **24** adopts a chair conformation with an equatorial 2-phenyl substituent (Figure 11) and, interestingly, **28** adopts a twist conformation (Figure 12)! This finding for **28** lends credence to our suggestion that a twist conformer may contribute to the conformational equilibria for **24–28**.

$^{31}\text{P}$  and  $^{13}\text{C}$  NMR.<sup>11</sup> Phosphorus-31 NMR chemical shifts were determined for a variety of 1,3,2-dithiaphosphorinanes. A tabulation of data, and accompanying discussion (employing ref 45–48), is presented in the microfilm supplement.<sup>16</sup>

(44) Martin, J.; Robert, J. B., *Org. Magn. Reson.*, 9, 637 (1977).

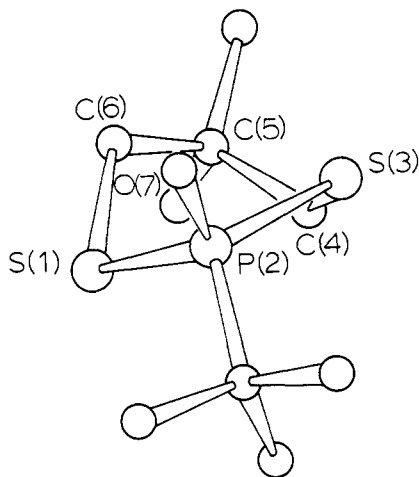

Figure 12. Structure and solid-state conformation of **28**.

Carbon-13 chemical shifts and  $^{31}\text{P}$ - $^{13}\text{C}$  coupling constants for a number of tricoordinate and tetracoordinate 1,3,2-dithiaphosphorinanes are collected in Table V. Although much could be said about these data in general, we will only discuss here trends associated with stereochemistry.

Comparison of anancomeric phosphines **11b** and **11a** reveals several important features relevant to stereochemistry. The axial 2-phenyl group in **11b** causes a 5-ppm shielding of the 4,6 carbons, a well-known steric compression shift ( $\gamma$  effect).<sup>10a,49</sup> This  $\gamma$  effect is also observed for **7a** and **7b**, intimating that **7b** mainly exists as a chair conformer with equatorial 2-phenyl and 5-*tert*-butyl groups. One may also compare  $\delta_{4,6}$  for **12** (axial phenyl) with that for **17** (equatorial *tert*-butyl). This  $\gamma$  effect has been reported for 1,3,2-dithiaphosphorinanes.<sup>15a,46</sup> The chemical shifts for the  $\alpha$  carbon of the aromatic ring in **11a** and **11b** also are sensitive to spatial orientation:  $\text{C}_\alpha$  is shifted 3.5 ppm upfield for the equatorial phenyl group (**11a**). Several  $^{31}\text{P}$ - $^{13}\text{C}$  coupling constants in **11b** and **11a** are sensitive to stereochemical factors. Great differences are observed for  $^3J_{\text{PC}_\alpha}$  (larger in **11b**),  $^3J_{\text{PC}(5)}$  (larger in **11a**), and  $^1J_{\text{PC}(\alpha)}$  (larger in **11b**).<sup>50</sup> In **7a** and **7b**,  $^3J_{\text{PC}(5)}$  is also much larger in the isomer (**7b**) with an equatorial 2-phenyl group. Robert and co-workers have recorded the extreme sensitivity of  $^3J_{\text{PC}(5)}$  to the orientation of substituents on phosphorus in tricoordinate 4,5,6-unsubstituted 1,3,2-dithiaphosphorinanes; values range from 0–1.5 Hz for 100% axial to 11–12 Hz for 100% equatorial.<sup>15a,51</sup> It is thus interesting to note the  $^3J_{\text{PC}(5)}$  values of 0 Hz for **12** and 4.9 Hz for **17**, which suggest an exclusive axial phenyl for **12** and conformational averaging for **17**. However, the 5,5-dimethyl substitution may be perturbing  $^3J_{\text{PC}(5)}$  in **17** by ring distortion (cf. **11a** and **11b**).

A stereospecificity of  $^3J_{\text{PC}_\alpha}$  is observed for 4-methyl-1,3,2-dithiaphosphorinane diastereomers with predominantly axial

2-substituents and either an axial or equatorial 4-methyl group.<sup>46</sup> Also, stereospecific four-bond couplings, dependent on phosphorus orientation, are observed in **12** and **17**, which supports chair conformers with axial phenyl and equatorial *tert*-butyl groups, respectively.

In **7a** and **7b**,  $^2J_{\text{PC}(4,6)}$  is stereospecific, but this effect is absent in **11b** and **11a**. This disparity may be a consequence of ring distortion, or likely conformational averaging of **7b**. Values of  $^2J_{\text{PC}(4,6)}$  for tricoordinate 1,3,2-dithiaphosphorinanes have been reported to fall into a range of 9–15.5 Hz, and they are not especially sensitive to stereochemistry.<sup>15a,46,52</sup>

For the 2-oxo-1,3,2-dithiaphosphorinanes, the anancomeric chair derivatives **22** and **23** can be used to establish standards for stereospecificity of  $^{13}\text{C}$  NMR parameters. The axial 2-phenyl orientation in **23** does not give rise to a  $\gamma$  shielding effect on  $\text{C}_{4,6}$  (of  $\sim 3$  ppm),<sup>53</sup> and the phenyl  $\alpha$  carbon is deshielded by 2.5 ppm. The  $^2J_{\text{PC}(4,6)}$  and  $^3J_{\text{PC}(5)}$  values for the axial 2-phenyl orientation in **23** does not give rise to a  $\gamma$  shielding effect on  $\text{C}_{4,6}$  (of  $\sim 3$  ppm),<sup>53</sup> and the phenyl  $\alpha$  carbon is deshielded by 2.5 ppm. The  $^2J_{\text{PC}(4,6)}$  and  $^3J_{\text{PC}(5)}$  values for the axial 2-phenyl isomer **23** are  $\sim 4$  Hz and those for the equatorial 2-phenyl isomer **22** are 2 Hz. The coupling to the  $\alpha$  carbon of the phenyl group,  $^1J_{\text{PC}(\alpha)}$ , is especially sensitive to stereochemistry at phosphorus; it is 105.5 Hz for **23** and 110.6 Hz for **22**. Highly biased chair derivative **5**, possessing equatorial 5-*tert*-butyl and 2-phenyl groups, shows  $^{13}\text{C}$  NMR data which agree with those for **22**. Thus,  $\delta^{13}\text{C}$  for the  $\alpha$  carbon of the phenyl ring is 133.3 Hz (vs. 132.2 for **22**) and  $^1J_{\text{PC}(\alpha)}$  is 111.5 Hz (vs. 110.6 for **22**);  $^2J_{\text{C}(4,6)}$  and  $^3J_{\text{PC}(5)}$  are 3.3 and 1.5 Hz (vs. 2 and 2 Hz for **22**). Twist isomer **6** has a  $\delta^{13}\text{C}$  for the phenyl  $\alpha$  carbon of 135.5 Hz (vs. 134.7 for **23**), a  $^2J_{\text{C}(4,6)}$  of 3.9 Hz (vs. 4.0 for **23**), and a  $^3J_{\text{C}(5)}$  of 2.9 Hz (vs. 3.9 for **23**), which unfortunately also show agreement. However, the  $^1J_{\text{PC}(\alpha)}$  for **6** of 113.3 Hz is incompatible with the value of 105.5 Hz for **23**. This anomaly in  $^1J_{\text{PC}(\alpha)}$  for **6** may reflect the prevalence of a twist conformation (or a chair conformation with axial 5-*tert*-butyl and equatorial 2-phenyl groups). Compound **24**, which is a conformational mixture, shows the following values:  $\delta\text{C}_\alpha = 134.6$ ,  $^2J_{\text{PC}(4,6)} = 3.2$  Hz,  $^3J_{\text{PC}(5)} = 2.2$  Hz, and  $^1J_{\text{PC}(\alpha)} = 112$  Hz. The high value for  $^1J_{\text{PC}(\alpha)}$  of 112 Hz correlates with an equatorial-phenyl chair conformer (110.6 for **22**; 111.5 for **5**) or a twist conformer (113.3 for **6**), but the high value for  $\delta\text{C}_\alpha$  of 134.6 correlates with an axial-phenyl chair conformer (134.7 for **23**) or a twist conformer (135.5 for **6**). Since these data for **24** support contradictory chair conformers, they tend to suggest a conformational equilibrium comprised mainly of twist conformers, with possibly some contribution from an equatorial-phenyl chair conformer (the latter of which imparts some averaging to the values of  $\delta\text{C}_\alpha$  and  $^1J_{\text{PC}(\alpha)}$  for **24**).

Phosphine sulfides **20a** and **20b** are highly biased chair conformations with an equatorial 5-*tert*-butyl group and axial or equatorial 2-phenyl groups, respectively. Of the  $^{13}\text{C}$  NMR parameters, significant stereospecificity is seen for  $\delta\text{C}_\alpha$  (136.0 for **20a**; 132.5 for **20b**),  $\delta\text{C}_{4,6}$  (33.5 for **20a**; 31.7 for **20b**),<sup>53</sup>  $\delta\text{C}_5$  (45.3 for **20a**; 47.5 for **20b**), and  $^1J_{\text{PC}(\alpha)}$  (82.8 Hz for **20a**; 87.9 Hz for **20b**). The  $^1J_{\text{PC}(\alpha)}$  value for an axial phenyl was 5 Hz smaller than that for an equatorial phenyl. This exact characteristic was observed for the rigid 2-oxo derivatives **23** and **22**. With conformationally rigid 1-methyl-4-*tert*-butyl-4-hydroxyphosphorinane-1-sulfides,  $^1J_{\text{PC}(\alpha)}$  in the axial methyl isomer was 3 Hz smaller than that in the equatorial methyl isomer.<sup>54</sup> Interestingly, **31**, which is a mixture of (probably) chair conformers (vide supra),<sup>44</sup> displays average values of  $^1J_{\text{PC}(\alpha)} = 85.9$  Hz

(45) The  $\delta^{31}\text{P}$  value for phenylbis(ethylthio)phosphine (75.0 ppm) illustrates the effect of free rotation, which would be prevalent in a flexible twist conformer. We suppose that a twist form would exhibit a very strong downfield displacement of  $\delta^{31}\text{P}$ .

(46) Nifant'ev, E. E.; Borisenko, A. A.; Zavalishina, A. I.; Sorokina, S. F., *Dokl. Akad. Nauk SSSR (Engl. Transl.)*, **219**, 839 (1974).

(47) (a) McPhail, A. T.; Breen, J. J.; Somers, J. H.; Steele, J. C. H., Jr.; Quin, L. D., *Chem. Commun.*, 1020 (1971); (b) McPhail, A. T.; Luhan, P. A.; Featherman, S. I.; Quin, L. D., *J. Am. Chem. Soc.*, **94**, 2126 (1972).

(48) Benrude, W. G.; Tan, H.-W., *J. Am. Chem. Soc.*, **95**, 4666 (1973).

(49) (a) Levy, G. C.; Nelson, G. L., "Carbon-13 NMR for Organic Chemists", Wiley, New York, 1972; (b) Dalling, D. K.; Grant, D. M., *J. Am. Chem. Soc.*, **94**, 5318 (1972).

(50) (a) Substituent one-bond coupling constants,  $^1J_{\text{PC}_\alpha}$ , for a conformationally biased isomeric pair of tricoordinate phosphorinanes, show stereospecificity in the same manner:  $J = 16$  Hz for axial  $\text{CH}_3$  and 12 Hz for equatorial  $\text{CH}_3$ .<sup>50b</sup> (b) Featherman, S. I.; Quin, L. D., *Tetrahedron Lett.*, 1955 (1973); Featherman, S. I.; Lee, S. O.; Quin, L. D., *J. Org. Chem.*, **39**, 2899 (1974).

(51) (a) In tricoordinate 1,3,2-dioxaphosphorinanes  $^3J_{\text{PC}(5)}$  values are also very sensitive to orientation at phosphorus (equatorial,  $\sim 14$  Hz; axial,  $\sim 4$  Hz),<sup>51b</sup> whereas this coupling is small and nonstereospecific in phosphorinanes.<sup>50b</sup> (b) Haemers, M.; Ottinger, R.; Zimmerman, D.; Reisse, J., *Tetrahedron Lett.*, 2241 (1973).

(52) Values for  $^2J_{\text{PC}}$  in tricoordinate 1,3,2-dioxaphosphorinanes are small (2–3 Hz) and insensitive to the steric arrangement at phosphorus,<sup>51b</sup> whereas these values in phosphorinanes are very sensitive to the stereochemistry at phosphorus.<sup>50b</sup>

(53) (a) The  $\gamma$  shielding by an axial oxygen or an axial sulfur exceeds that of an axial 1- $\text{CH}_3$  group in the phosphorinane system.<sup>53b</sup> This phenomenon is also evident in the 1,3,2-dithiaphosphorinane system for O or S vs. phenyl. (b) Quin, L. D.; Lee, S. O., *J. Org. Chem.*, **43**, 1424 (1978); Quin, L. D.; Gordon, M. D.; Lee, S. O., *Org. Magn. Reson.*, **6**, 503 (1974).

(54) Quin, L. D.; McPhail, A. T.; Lee, S. O.; Onan, K. D., *Tetrahedron Lett.*, 3473 (1974).

(between 82.8 and 87.9 Hz) and  $\delta C_\alpha = 133.9$  (between 132.5 and 136.0) [also,  $\delta C_\beta = 130.6$  (between 130.1 and 131.4), and  $\delta C_\gamma = 132.7$  (between 132.2 and 133.2)].

$^{13}\text{C}$  NMR has obvious utility in making structural and stereochemical assignments with the dithiaphosphorinane derivatives, but some caution must be exercised. Trends in the tricoordinate series are not necessarily applicable in the tetracoordinate series (e.g., the  $\gamma$  effect of phosphorus substituents; relative magnitude of isomeric  $^{31}\text{P}$ - $^{13}\text{C}$  coupling constants, such as  $^1J_{\text{PC}(\alpha)}$ ). Within each series, we have found that  $^{13}\text{C}$  chemical shifts and, particularly,  $^{31}\text{P}$ - $^{13}\text{C}$  one-bond coupling constants for the *substituents on phosphorus* can be useful in stereochemical studies.

**Twist Conformations.** Saturated homocyclic and heterocyclic six-membered rings generally exhibit a strong preference for the chair conformation over nonchair forms ( $\Delta H^\circ = \sim 3\text{--}8$  kcal/mol).<sup>55</sup> Special ring modifications or severe steric biasing influences can afford a predisposition to twist or other nonchair structures, but molecules that inherently favor a twist conformation in unstrained situations are rare.<sup>55a,56</sup> Since certain phosphorus-containing cyclohexanes appear to have an inclination to adopt twist structures in solution and in the solid state, it is appropriate to discuss this topic as it applies to the phosphorus compounds and related molecules.

We have reported that **6** populates a twist form significantly in solution, while **5** is predominantly a chair conformer, and that both **6** and **5** adopt a twist conformation in the solid state.<sup>16</sup> Bentrude and co-workers found that both 1,3,2-oxazaphosphorinane isomers **33a** and **33b** assume a twist conformation in the solid state and that **33a** is primarily a twist form in solution.<sup>57</sup>

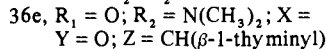
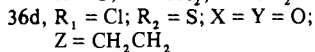
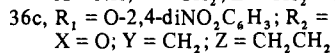
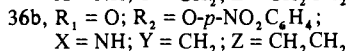
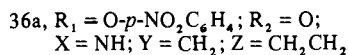
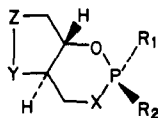
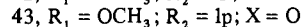
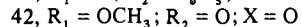
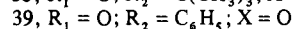
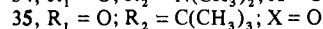
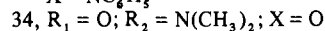
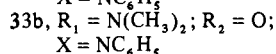
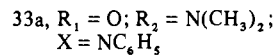
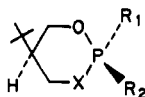

(55) Kellie, G. M.; Riddell, F. G., *Top. Stereochem.*, **8**, 225 (1974); (b) Pihlaja, K., *J. Chem. Soc., Perkin Trans.*, **2**, 890 (1974); (c) Bushweller, C. H.; Bhat, G.; Lentendre, L. J.; Brunelle, J. A.; Bilofsky, H. S.; Ruben, H.; Templeton, D. H.; Zalkin, A., *J. Am. Chem. Soc.*, **97**, 65 (1975); (d) Squillacote, M.; Sheridan, R. S.; Chapman, O. L.; Anet, R. A. L., *J. Am. Chem. Soc.*, **97**, 3244 (1975); (e) Allinger, N. L.; Hickey, M. J.; Kas, J., *J. Am. Chem. Soc.*, **98**, 2741 (1976).

(56) Introduction into cyclohexane of (1)  $\text{sp}^2$ -hybridized atoms, (2) substituents imposing severe strain (e.g., axial *tert*-butyl or 1,3-diaxial substituents) in the chair form, which can be relieved in the twist form, (3) constraint by chemical bonding (e.g., twistane), or (4) alternate pairs of disulfide linkages can lower the chair/twist energy difference to a point where the twist form predominates.<sup>54a</sup>

(57) Bajwa, G. S.; Bentrude, W. G.; Pantaleo, N. S.; Newton, M. G.; Hargis, J. H., *J. Am. Chem. Soc.*, **101**, 1602 (1979). Interestingly, replacement of the *N*-phenyl group in **33a** by a hydrogen causes a displacement of the twist-chair equilibrium strongly toward the chair conformation, see: Chandrasekaran, S.; Bentrude, W. G. *Tetrahedron Lett.*, 4671 (1980).

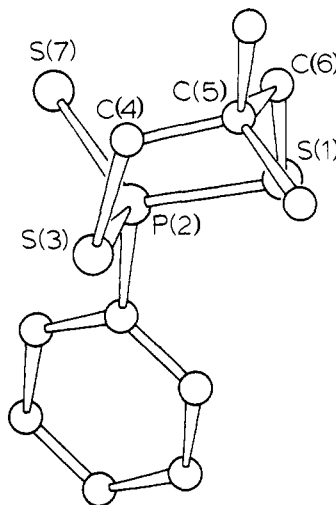
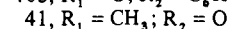
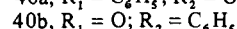
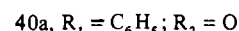
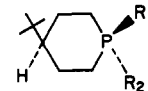
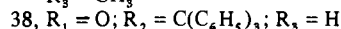
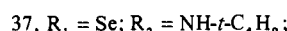
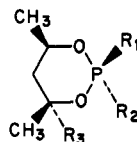

Figure 13. Structure and solid-state conformation of **31**.

Dioxaphosphorinane analogue **34** also appears to populate a twist conformer significantly ( $\sim 60\%$ ) in solution,<sup>48</sup> and **35** was assigned a boat conformation in solution.<sup>58</sup> Gorenstein and Rowell reported that oxazaphosphorinane **36a** adopts a twist conformation in solution, but that its corresponding diastereomer (**36b**) assumes a chair conformation with an axial aryloxy substituent.<sup>59a</sup> The dioxaphosphorinane analogue of **36a** (**36a** with  $X = \text{O}$ ) did not have as great a tendency to adopt a twist conformation (it was suggested to have about 50% twist conformer in an aprotic medium).<sup>59b</sup> In comparison, dioxaphosphorinanes **36c**<sup>59b</sup> and **36d**<sup>59c</sup> seem to exist largely in a twist conformation. Thymidine cyclic nucleotide **36e** ( $R_p$  isomer) favors a twist conformation ( $\sim 75\%$  in toluene), whereas the  $S_p$  isomer (not shown) strongly favors a chair conformation with an equatorial dimethylamino group.<sup>60</sup> Very sterically biased 1,3,2-dioxaphosphorinane **37** possesses a twist conformation in the solid state,<sup>61a</sup> whereas **38** adopts a highly flattened chair ("chaise-lounge") conformation.<sup>61b</sup>



It should be noted that nonchair conformations prevail in 1,3,2-dioxaphosphorinanes only where a highly thermodynamically unfavored disposition of phosphorus substituents would otherwise occur, in conjunction with a highly unfavored alternative chair structure (viz., **34**, **35**, **36a**, **36c**, **36d**, **36e**, **37**, **38**). The 1,3,2-oxazaphosphorinane system may have an enhanced propensity toward twist conformations compared to the 1,3,2-dioxaphosphorinane series, but the ring nitrogen substituent may play a modulating role.<sup>57,59</sup>

The 1,3,2-dithiaphosphorinane ring system has an increased preference for the twist form relative to the 1,3,2-dioxaphosphorinane and phosphorinane systems. For example, **39**, the oxygen isostere of **6**, exists chiefly in a chair conformation in solution,<sup>62</sup> and the carbon isostere, **40a**, shows no evidence for a

(58) Bentrude, W. G.; Yee, K. C., *J. Chem. Soc., Chem. Commun.*, 169 (1972).

(59) (a) Gorenstein, D. G.; Rowell, R., *J. Am. Chem. Soc.*, **101**, 4925 (1979); (b) Gorenstein, D. G.; Rowell, R.; Findlay, J., *J. Am. Chem. Soc.*, **102**, 5077 (1980); (c) Bouchu, D.; Dreux, J., *Tetrahedron Lett.*, 2513 (1980).

(60) Sopchik, A. E.; Bentrude, W. G., *Tetrahedron Lett.*, 4679 (1980).

(61) (a) Kinast, R.; Stec, W. J.; Krüger, C., *Phosphorus Sulfur*, **4**, 295 (1978); (b) Drew, M. G. B.; Rodgers, J.; White, D. W.; Verkade, J. G., *Chem. Commun.*, 227 (1971); Drew, M. G. B.; Rodgers, J., *Acta Crystallogr., Sect. B*, **28**, 924 (1972).

twist form.<sup>34d,63</sup> In the solid state, the 1,3,2-dioxaphosphorinanes and phosphorinanes are not prone to adopt a twist conformation. For example, **40b** is a chair with equatorial 1-phenyl and 4-*tert*-butyl groups,<sup>34d</sup> **41** is a chair with equatorial 5-*tert*-butyl and axial 2-methyl groups,<sup>64</sup> and **42** is a chair with axial 5-*tert*-butyl and 2-methoxy groups.<sup>65</sup>

Indeed, we have now discovered a completely unconstrained 2-oxo-1,3,2-dithiaphosphorinane that possesses a twist conformation in the solid state, namely **28**.<sup>26</sup> However, **19**,<sup>42</sup> the 5-*tert*-butyl congener of **28**, is a chair conformer with equatorial 2- and 5-*tert*-butyl groups.<sup>26</sup> Also, by contrast, **24**, the 2-phenyl analogue of **28**, adopts a chair structure with an equatorial 2-phenyl group in the solid state.<sup>26</sup> X-ray analysis of **22** and **23** disclosed chair conformers for each with diequatorial 4,6-dimethyl groups and an equatorial or axial 2-phenyl group, respectively<sup>26</sup> (chair conformations are also adopted in solution). Also, X-ray analysis of **20a**, the 2-thiono analogue of **6**, showed a chair conformation with equatorial 5-*tert*-butyl and axial 2-phenyl groups<sup>26</sup> (chair conformations are adopted for both **20a** and **20b** in solution). With respect to the solid-state properties of unconstrained 2-thiono compounds, we have found that **32** assumes a chair conformation with an equatorial 2-phenyl group (Figure 13),<sup>26</sup> and Robert and co-workers have reported that **30c** and **30e–30g** display only chair conformations.<sup>66</sup> From our <sup>1</sup>H and <sup>13</sup>C NMR data, we have suggested that twist conformers participate significantly in the conformational equilibria of 2-oxo-5,5-dimethyl-1,3,2-dithiaphosphorinanes in solution; however, this does not appear to be as likely with the 2-thiono-5,5-dimethyl analogues.

Replacement of methylene groups of cyclohexane by sulfur atoms can lower the chair–twist energy difference. For example, while cyclohexane has a  $\Delta H^\circ$  (chair–twist) of  $\sim 5.3$ – $6.0$  kcal/mol,<sup>55b,55d</sup> the value for 1,3-dithiane drops to  $\sim 3.4$ – $4.0$  kcal/mol.<sup>18,55b,67</sup> Furthermore, an entropy term ( $\Delta S^\circ_{ct}$ ) favoring the twist form lowers the free-energy difference such that  $\Delta G^\circ_{ct}$  (25 °C) for 1,3-dithiane is only  $\sim 1.7$ – $2.6$  kcal/mol.<sup>18,55b</sup> Likewise,  $\Delta G^\circ_{ct}$  for the 1,2,4,5-tetrathiane ring system is lowered to such an extent that the twist form can be preferred;<sup>55c,68</sup> the twist form is especially favored in tetrathianes bearing geminal alkyl substituents.<sup>55c,55e</sup> Empirical force-field calculations of Allinger,<sup>55e</sup> dealing with disulfide linkages, acknowledge intrinsically depressed energy differences ( $\Delta H^\circ_{ct}$ ) between chair and nonchair forms for (unsubstituted) 1,2,4,5-tetrathiane (1.1 kcal/mol),<sup>69</sup> 1,2-dithiane (3.9 kcal/mol), and 1,2,3-trithiane<sup>70</sup> (3.3 kcal/mol), relative to cyclohexane; however, other multisulfur ring systems (1,2,3,4-tetrathiane, pentathiane, and cyclohexasulfur<sup>71</sup>) have elevated energy differences. Although the relatively small  $\Delta G^\circ_{ct}$  for the 2-oxo-1,3,2-dithiaphosphorinane system is probably imparted by the 1,3 sulfur atoms, analogous to 1,3-dithiane, the presence of a phosphorus atom could further diminish  $\Delta G^\circ_{ct}$ .<sup>72,73</sup> The 5,5-

dimethyl substitution in **24–28** may also assist in favoring the twist conformer.

The fact that the twist form is adopted by 2-oxo-1,3,2-dithiaphosphorinanes **5**, **6**, and **28** in the solid state suggests that  $\Delta G^\circ_{ct}$  may be quite low ( $< 1$  kcal/mol). Unfortunately, crystal-packing forces, which can have a considerable influence on the conformation assumed,<sup>69</sup> are difficult to estimate. Nevertheless, the prevalence of a twist form in the solution conformational equilibrium for **6**, and, probably, in the equilibria for **24–28**, signifies an upper limit for  $\Delta G^\circ_{ct}$  of  $\sim 1$  kcal/mol.

## Experimental Section

**General Procedures.** All melting points (determined on a Mel-Temp hot-stage apparatus) and boiling points are uncorrected. IR spectra were recorded on Perkin-Elmer 457 or 521 spectrophotometers (s = strong, m = medium, w = weak); liquid samples were neat and solid samples were in KBr, unless otherwise specified. <sup>1</sup>H NMR spectra were obtained on Varian A-60, HA-100, or HR-220 spectrometers; on a Bruker WH-250 spectrometer (250 MHz); or on a Perkin-Elmer R-32 spectrometer (90 MHz). Chemical shifts are reported in parts per million downfield from a Me<sub>4</sub>Si internal reference. Proton decoupling was achieved on the HA-100 or R-32 instrument; variable-temperature studies were carried out on the A-60 or R-32 instruments. The peak-splitting designations are as follows: s = singlet, d = doublet, t = triplet, q = quartet, p = pentet, hx = hexet, dd = double of doublets, and m = multiplet (br = broadened). Carbon-13 NMR spectra were recorded on a JEOL FX60Q spectrometer (15.00 MHz), unless otherwise noted; chemical shifts are reported in parts per million downfield from Me<sub>4</sub>Si. Both proton noise-decoupled and off-resonance-decoupled <sup>13</sup>C spectra were determined; only noise-decoupled data are reported. Quaternary carbons were enhanced, when necessary, by low-power, off-resonance decoupling. Phosphorus-31 NMR spectra were recorded in benzene at 40.5 MHz on a HA-100 spectrometer using a reference capillary containing 85% H<sub>3</sub>PO<sub>4</sub>. The spectra were calibrated by the sideband technique in most cases.<sup>74</sup> The <sup>31</sup>P chemical shifts, reported in parts per million downfield from H<sub>3</sub>PO<sub>4</sub>, are an average of at least two scans and have a standard deviation of  $\pm 0.3$  ppm unless otherwise denoted. Analyses of <sup>1</sup>H NMR spectra were performed by using a modified version of the LAOCOON 3 NMR program<sup>21</sup> (modified to operate on the Burroughs 5500 computer). Calculated spectra were plotted by assigning a Lorentzian lineshape. Determination of the chemical shifts of the A and B protons of AB patterns was performed by utilizing the equation:  $\nu_{AB} = \sqrt{(\nu_1 - \nu_4)(\nu_2 - \nu_3)}$ .<sup>75</sup> Mass spectra were recorded on a Perkin-Elmer Hitachi RMU-6 mass spectrometer at an electron energy of 70 eV. Microanalyses were performed by Alfred Bernhardt Mikroanalytisches Laboratorium, West Germany. All reactions involving trivalent phosphorus compounds were conducted under an atmosphere of dry nitrogen except for oxidations of nonstereoisomeric compounds. GLC analyses of product mixtures and purified samples were performed on a Hewlett-Packard Model 5250B instrument coupled to an L & N Model W recorder equipped with a Disc integrator. Preparative GLC was also performed on this instrument. Analyses were carried out on 6 ft  $\times$  1/8 in. or 10 ft  $\times$  1/8 in. stainless steel columns packed with 10% OV-1 on 80/100 mesh Chromosorb W, unless otherwise noted. Preparative work was done on a 10 ft  $\times$  1/4 in. aluminum column.

**Materials.** Methylchlorophosphine was kindly donated by Ethyl Corp., Baton Rouge, LA. Ethyl- and *tert*-butyldichlorophosphines were purchased from Orgmet, Inc., Hampstead, NH. Phenylphosphonyl dichloride was obtained as a free sample from Stauffer Chemical Co. (Specialties), New York, NY. Triethylamine and pyridine were distilled from potassium hydroxide and stored over molecular sieves (3A). Dimethylformamide (DMF) was distilled from calcium hydride and stored over molecular sieves (3A). All solvents were reagent grade or better, except for commercial solvent mixtures. *o*-Dichlorobenzene and 1,2,4-trichlorobenzene were distilled from calcium hydride and stored over anhyd K<sub>2</sub>CO<sub>3</sub>. *meso*-2,4-Pentanedithiol, 2-*tert*-butyl-1,3-propanedithiol, 2,2-dimethyl-1,3-propanedithiol, and 2-methyl-1,3-propanedithiol were

(73) Interestingly, **i** adopts a twist conformation in the solid state; see: Einstein, F. W. B.; Penfold, B. R.; Tapsell, Q. T., *Inorg. Chem.*, **4**, 186 (1965).

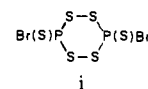

(74) Crutchfield, M. M.; Dungan, C. H.; Letcher, J. H.; Mark, V.; Van Wazer, J. R., *Top. Phosphorus Chem.*, **5**, 40–41 (1967).

(75) Bhacca, N.; Williams, D., "Application of NMR Spectroscopy in Organic Chemistry", Holden-Day, San Francisco, 1964.

(62) Bentrude, W. G.; Tan, H.; Yee, K. C., *J. Am. Chem. Soc.*, **94**, 3264 (1972).

(63) Venkataramu, S. D.; Berlin, K. D.; Ealick, S. E.; Baker, J. R.; Nichols, S.; van der Helm, D., *Phosphorus Sulfur*, **7**, 133 (1979).

(64) Haque, M.; Caughlan, C. N.; Hargis, J. H.; Bentrude, W. G., *J. Chem. Soc. A*, 1786 (1970).

(65) Warrent, R. W.; Caughlan, C. N.; Hargis, J. H.; Yee, K. C.; Bentrude, W. G., *J. Org. Chem.*, **43**, 4266 (1978).

(66) Grand, A.; Martin, J.; Robert, J. B., *Acta Crystallogr., Sect. B*, **B32**, 1244 (1975); Grand, A.; Robert, J. B.; Filhol, A., *Acta Crystallogr., Sect. B*, **33**, 1526 (1977).

(67) (a) Oxygen atoms tend to raise  $\Delta H^\circ_{ct}$ , which for 1,3-dioxane is  $\sim 8$  kcal/mol.<sup>67b</sup> (b) Clay, R. M.; Kellie, G. M.; Riddell, F. G., *J. Am. Chem. Soc.*, **95**, 4632 (1973).

(68) Guimon, M. F.; Guimon, C.; Metras, F.; Pfister-Guillouzo, G., *J. Am. Chem. Soc.*, **98**, 2078 (1976).

(69) 1,2,4,5-Tetrathiane derivatives have variable solid/solution preferences: chair/chair, twist/twist, and chair/twist.<sup>55c,68</sup> 3,3,6,6-Tetramethyl-1,2,4,5-tetrathiane<sup>55c</sup> has a twist conformation in the solid state, in solution, and in the gas phase.<sup>55c,68</sup>

(70) An X-ray structure determination of 1,2,3-trithian-5-yl *N*-methylcarbamate showed the ring in a chair conformation; see: Kato, A.; Mashimoto, Y.; Otsuka, I.; Nakatsu, K., *Chem. Lett.*, 1219 (1978).

(71) The X-ray structure of S<sub>6</sub> exhibits a D<sub>3d</sub> chair structure; see: Steidel, J.; Pickardt, J.; Steudel, R., *Z. Naturforsch. B*, **33**, 1554 (1978).

(72) For **35**,  $\Delta G^\circ_{ct}$  may be as low as 1 kcal/mol,<sup>58</sup> and  $\Delta G^\circ_{ct}$  for phosphine **43** was suggested to be 1.5–2.0 kcal/mol.<sup>13</sup>

prepared from diol-ditosylates, as previously described.<sup>18,76</sup>

**1,3,2-Dithiaphosphorinanes. General Condensation Procedure.** The title compounds were prepared by the simultaneous, dropwise addition of the appropriate dichlorophosphine in dry ether (~1 M) and the appropriate dithiol in dry ether (~1 M) to an ice-cooled, stirred solution of triethylamine in dry ether.<sup>77</sup> Equimolar proportions of the dithiol and dichlorophosphine were used as well as 50% molar excess of triethylamine. When addition was completed, the mixture was allowed to warm to room temperature. It was then filtered and the filtrate was concentrated at reduced pressure. If the residue contained some triethylamine hydrochloride, it was diluted with a threefold volume of dry ether and the solution was filtered. The clear solution was reconstituted and the residue was usually distilled. However, in a few instances where solidification occurred, sublimation was also employed to separate the desired product from polymeric substance. Recrystallization was usually used for additional purification of solid compounds, and evaporative microdistillation was used for liquids. Samples for elemental analyses were prepared by sublimation of pure material (solids) or by preparative GLC (liquids). Because of the air sensitivity of the tricoordinate compounds, microanalyses were also satisfied by 2-oxo derivatives, obtained by H<sub>2</sub>O<sub>2</sub> oxidation. Purification of isomers was accomplished by fractional crystallization. Physical and analytical data for tricoordinate 1,3,2-dithiaphosphorinanes appear in the microfilm supplement.<sup>76</sup>

**2-Oxo- and 2-Thiono-1,3,2-dithiaphosphorinanes. General Condensation Procedure.** The condensation procedure was the same as the one used for the 1,3,2-dithiaphosphorinanes (above), with replacement of the dichlorophosphine by a phosphonic dichloride or thiophosphonic dichloride. Physical and analytical data for 2-oxo and 2-thiono derivatives are furnished in the microfilm supplement.<sup>76</sup>

**2-Oxo-1,3,2-dithiaphosphorinanes. General Oxidation Procedure.**<sup>16a</sup> The tricoordinate compound (0.2–0.3 mmol) was combined with 2 mL of CH<sub>2</sub>Cl<sub>2</sub> and 1 mL of 3% hydrogen peroxide. The mixture was stirred overnight under a nitrogen atmosphere in cases where stereochemistry was involved, otherwise in air. The CH<sub>2</sub>Cl<sub>2</sub> solution was separated and the aqueous phase was extracted with some fresh solvent. Evaporation of the solvent on a steam bath left an oil which crystallized when permitted to stand or when triturated with *n*-pentane. Crude yields were always >90%. Purification was effected by recrystallization from ether–pentane or hexane–ethyl acetate. Sublimation of pure material provided the analytical sample. Physical and analytical data on 2-oxo compounds are given in the microfilm supplement.<sup>76</sup>

**2-Phenyl-*cis*-4,6-dimethyl-1,3,2-dithiaphosphorinane (11a and 11b).** In the manner described above, *meso*-2,4-pentanedithiol (1.36 g, 0.01 mol) in 20 mL of dry ether and phenyldichlorophosphine (1.79 g, 0.01 mol) in 20 mL of dry ether were added synchronously, dropwise, to a stirred, ice-cooled solution of triethylamine (4.04 g, 0.04 mol) in 50 mL of dry ether. After addition, the mixture was allowed to warm to room temperature (~1 h). It was filtered and the residue was rinsed with dry ether. The solvent was removed and distillation of the crude product gave (after a small forerun) 1.4 g of viscous oil, bp 113–118 °C (0.02 torr), *n*<sub>D</sub><sup>25</sup> 1.6225. Microdistillation of a small portion provided an analytical sample, *n*<sub>D</sub><sup>24.5</sup> 1.6240. Anal. (mixture of isomers) Calcd for C<sub>11</sub>H<sub>13</sub>PS<sub>2</sub>: C, 54.52; H, 6.24. Found: C, 54.35; H, 6.02. <sup>1</sup>H NMR (C<sub>6</sub>D<sub>6</sub>, 100 MHz) δ 0.95 (dd, *J* = 7.0, 1.2 Hz, CH<sub>3</sub> in 11b), 1.20 (dd, *J* = 7.0, 1.2 Hz, CH<sub>3</sub> in 11a), 0.9–1.8 (m, 5-H), 2.55 (m, 0.8, 4,6-H), 2.90 (m, 1.2, 4,6-H), 7.0–7.3 (m, 3), 7.6–7.9 (m, 2); ratio of 11b and 11a was 40:60 (the less stable isomer predominated), as determined from the height of the CH<sub>3</sub> signals and integration of the separate 4,6-H resonances. The 40:60 ratio (11b/11a) was also evident in the <sup>13</sup>C and <sup>31</sup>P NMR spectra of the isomeric mixture (δ<sup>31</sup>P: 11a, 63.5; 11b, 37.0).

**Separation and Equilibration of 11b and 11a.** The 40:60 mixture (11b/11a) was injected as a benzene solution onto various new 6 ft × 1/8 in. GLC columns: (A) 10% OV-1, (B) 10% Apiezon L, (C) 3% OV-17, and (D) 10% Carbowax 20M, all on 80/100 mesh Chromosorb W, between 170 and 200 °C. A fairly good separation was obtained on columns A and C at ~175 °C. With use of column A, a portion of the mixture was separated at 170 °C; the retention times were 13 and 14 min. Both collected samples crystallized. The first peak to elute became more and more abundant with each injection until a final ratio of ca. 90:10 (11b/11a) was achieved. This was caused by a progressively increasing equilibration of the isomers on the column, as the column aged. Injections of Silyl 8 column conditioner improved the column, slowing the increase in the amount of equilibration (but not preventing it). The first peak to elute was 11b, the more thermodynamically stable isomer, and the lesser component of the original mixture (<sup>1</sup>H NMR). Two

preparative GLC columns (6 ft × 1/4 in.) were prepared corresponding to columns A and C, and these were used to separate more material. They were "silylated" frequently to hinder equilibration but eventually had to be discarded. Analysis of the enriched mixtures on a freshly made, "silylated" column showed the first sample to be 93–95% of the more stable isomer (11b) and the second to be 79–81% of the less stable isomer (11a). Satisfactory elemental analyses were obtained for both enriched samples. Anal. Calcd for C<sub>11</sub>H<sub>13</sub>PS<sub>2</sub>: C, 54.52; H, 6.24. Found (11b-rich): C, 54.41; H, 6.14. Found (11a-rich): C, 54.40; H, 6.11.

The 91:9 equilibrium, which finally resulted on the degenerated column at 170 °C, affords Δ*G*<sub>170</sub> for 11 (catalysis of the equilibrium should not effect the equilibrium constant). Given *K* = 10.1, Δ*G*<sub>170</sub> = -2.05 kcal/mol. An attempt to study the equilibration of 11 by the method used for 7 was thwarted because of significant decomposition under the same conditions. However, a neat sample of 11b and 11a (40:60 mixture) was equilibrated in a sealed tube under argon at 130 °C for 5 h. The final isomer ratio was ca. 95:5 (11b/11a), determined by <sup>1</sup>H NMR integration. Given *K* = ~19, Δ*G*<sub>130</sub> = ~-2.3 kcal/mol. This range of approximate free-energy difference, -2 to -2.3 kcal/mol, is probably a good estimate of the energy difference between an axial and equatorial orientation of the *P*-phenyl group.

Careful recrystallization of a sample of ca. 90:10 mixture (11b/11a) from 90% aqueous methanol gave the more stable isomer 11b as a pure crystalline solid: mp 50.5–51.5 °C; <sup>1</sup>H NMR (C<sub>6</sub>D<sub>6</sub>, 90 MHz) δ 0.93 (dd, 6, <sup>3</sup>*J*<sub>HH</sub> = 6.8 Hz, <sup>4</sup>*J*<sub>PH</sub> = 1.0 Hz), 1.1–1.6 (m, 2), 2.3–2.7 (m, 2, <sup>3</sup>*J*<sub>HH</sub> = 7 Hz, <sup>3</sup>*J*<sub>HH</sub> = 10 Hz, <sup>3</sup>*J*<sub>HH</sub> = 3 Hz, <sup>3</sup>*J*<sub>PH</sub> = 3 Hz), 6.9–7.3 (m, 3), 7.7–8.0 (m, 2). Anal. for C, H, and S. These crystals were used in the X-ray analysis.

***t*-4, *t*-6-Dimethyl-*r*-2-oxo-2-phenyl-1,3,2-dithiaphosphorinane (22).** An equilibrated sample of 11a and 11b (ca. 5:95) was dissolved in methylene chloride and stirred overnight with excess 3% aqueous H<sub>2</sub>O<sub>2</sub>. The methylene chloride solution was concentrated and the residue was recrystallized from ethyl acetate to obtain colorless needles, mp 146–148 °C. TLC (ethyl acetate) indicated that 22 was isomerically pure and homogeneous. Anal. Calcd for C<sub>11</sub>H<sub>13</sub>S<sub>2</sub>PO: C, 51.14; H, 5.85. Found: C, 51.02; H, 5.77.

***c*-4, *c*-6-Dimethyl-*r*-2-oxo-2-phenyl-1,3,2-dithiaphosphorinane (23).** Solutions of *meso*-2,4-pentanedithiol (2.72 g, 20 mmol) in 60 mL of dry ether and phenylphosphonic dichloride (3.92 g, 20 mmol) in 60 mL of dry ether were added dropwise over a 1-h period to a solution of triethylamine (8.08 g, 80 mmol) in 150 mL of dry ether. The solution was stirred at room temperature for 3 h and filtered; the precipitate was washed thoroughly with ether. Evaporation of the combined filtrates gave ~5 g of solid residue. Recrystallization from ethyl acetate–hexane, and then hexane–methylene chloride, afforded colorless prisms, mp 134–135 °C. TLC (ethyl acetate) indicated that 23 was isomerically pure and homogeneous. Anal. Calcd for C<sub>11</sub>H<sub>13</sub>OPS<sub>2</sub>: C, 51.14; H, 5.85; S, 24.82. Found: C, 51.19; H, 5.87; S, 24.80.

**Stereospecific Oxidation of 11b to 23 with 3% Aqueous Hydrogen Peroxide.** A sample of 11b was oxidized stereospecifically to 23 by 3% H<sub>2</sub>O<sub>2</sub> (see above) in 91% yield. Recrystallization from hexane–ethyl acetate gave brilliant, prismatic needles: mp 143.5–145 °C; <sup>1</sup>H NMR (CDCl<sub>3</sub>) δ 1.44 (dd, 6, <sup>3</sup>*J*<sub>HH</sub> = 7 Hz, <sup>4</sup>*J*<sub>PH</sub> = 2.5 Hz), 1.89 (m, 2), 2.90 (m, 2), 7.50 (m, 3), 8.01 (m, 2); IR *ν*<sub>max</sub> 1195 (P=O) cm<sup>-1</sup>.

**2-Phenyl-2-thiono-5-*tert*-butyl-1,3,2-dithiaphosphorinane (20a and 20b).** Solutions of 2-*tert*-butyl-1,3-propanedithiol (1.69 g, 10 mmol) in 30 mL of dry ether and phenylthiophosphonic dichloride (1.56 g, 10 mmol) in 30 mL of dry ether were added dropwise to triethylamine (4.04 g, 4 mmol) in 75 mL of dry ether over a 1-h period. The mixture was stirred at room temperature for 1.5 h and filtered; the precipitate was washed thoroughly with ether. Evaporation of the solvent and recrystallization of the solid residue from ethyl acetate–hexane gave two fractions. The first fraction was recrystallized from ethyl acetate to give 20b, mp 168–170 °C. TLC (hexane–ethyl acetate, 9:1) separated the two isomers; 20b had the greater *R*<sub>f</sub> value. Anal. Calcd for C<sub>13</sub>H<sub>19</sub>PS<sub>2</sub>: C, 51.62; H, 6.33. Found: C, 51.90; H, 6.57. The second fraction was recrystallized from ethyl acetate–hexane to give 20a, mp 134–135 °C. Anal. Calcd for C<sub>13</sub>H<sub>19</sub>PS<sub>2</sub>: C, 51.62; H, 6.33. Found: C, 52.08; H, 6.67. Assignment of the isomers was accomplished via X-ray analysis and sulfurization of 7a to 20a (vide infra).

**Stereospecific Sulfurization of 7a to 20a.** Phosphine 7a<sup>16a</sup> (20 mg) and sulfur powder (20 mg) were heated in 1 mL of dry toluene under nitrogen at 100 °C for 24 h. The cooled solution was filtered and concentrated. TLC (hexane–ethyl acetate, 4:1) and <sup>1</sup>H NMR indicated that the product was identical with the lower melting sulfide 20a.

**2, *c*-5-Di-*tert*-butyl-*r*-2-oxo-1,3,2-dithiaphosphorinane (19).** Solutions of 2-*tert*-butyl-1,3-propanedithiol (1.69 g, 10 mmol) in 30 mL of dry ether and *tert*-butyldichlorophosphine (1.59 g, 10 mmol) in 30 mL of dry ether were added dropwise to triethylamine (4.04 g, 40 mmol) in 45 mL of ether over a 1-h period. The mixture was stirred at room temperature

(76) See paragraph at the end of this paper regarding supplementary material.

(77) For the *P*-*tert*-butyl derivatives, the addition was carried out at ambient temperature.

overnight and filtered; the precipitate was washed with ether. After evaporation of the solvent, the residue was dissolved in methylene chloride and stirred overnight with 6% aqueous hydrogen peroxide. Evaporation of the methylene chloride afforded a solid residue. Recrystallization from hexane (twice) afforded pure **19**, mp 168–170 °C. Anal. Calcd for C<sub>11</sub>H<sub>23</sub>OPS<sub>2</sub>: C, 49.59; H, 8.70. Found: C, 49.90; H, 8.52.

**Equilibration of 7 and Kinetics Measurements.** Approximately 0.2 M solutions of **7a**<sup>16a</sup> (>99% isomerically pure) in *o*-dichlorobenzene were sealed in NMR tubes in vacuo following three freeze–thaw cycles. A tube was heated in an oil bath at the desired temperature ( $\pm 1$  °C). Proton NMR was used to monitor the sample; electronic integration of the *tert*-butyl resonance provided quantitative information. No change was evidenced after 15 h at 100 °C. After 30 h at 150 °C, ~1% of the trans isomer (**7b**) was present. At 200 °C, 11% was present in 15 h, 15.6% in 30 h, and 15.4% in 42 h. Leaving this 85:15 solution at ambient temperature for 1 month resulted in an isomer ratio of 90:10. The equilibrium was also determined at 150 and 175 °C. At 175 °C, the equilibrium was approached from both sides, whereupon the same equilibrium constant was observed.

A kinetics study was undertaken at 175, 200, and 225 °C. The data therefrom are plotted in Figure 4. In an early study no special precautions were taken to avoid traces of acid—the *o*-dichlorobenzene was distilled from CaH<sub>2</sub> and was untreated and the NMR tube was cleaned with acetone and dried in an oven at 100 °C (curve C in Figure 4). Subsequently, the *o*-dichlorobenzene was stored over anhyd K<sub>2</sub>CO<sub>3</sub>, and the NMR tubes were treated as follows. The tubes containing 5% alcoholic KOH were allowed to stand for at least 1 h. The solution was decanted, and the tubes were rinsed with distilled water, rinsed liberally with acetone that had been distilled from anhyd K<sub>2</sub>CO<sub>3</sub> (apparatus cleaned with alcoholic KOH), and dried at 100 °C. Kinetic measurements were made under virtually acid-free conditions (curves A, B, and D in Figure 4), providing equilibrium data at 175 °C (6.7), 200 °C (5.4), and 225 °C (4.8). A plot of  $\ln K$  vs.  $1/T$  (see Table III) was fit to a least-squares straight line, and the slope ( $-\Delta H/R$ ) and intercept ( $\Delta S/R$ ) were determined.

The equilibrium represents a simple first-order reversible reaction. Accordingly, the rate law for this process<sup>78</sup> was applied. The uncatalyzed kinetic data were treated according to eq 5,<sup>78</sup> where  $A_0$  is the initial

$$\ln [(A_0 - A_{eq}) / (A - A_{eq})] = (k + k')t \quad (5)$$

percentage of **7a** (100),  $A_{eq}$  is the percentage of **7a** at equilibrium,  $A$  is the percentage of **7a** at time  $t$ , and  $(k + k')$  is the effective rate constant (i.e., the sum of the forward and backward rate constants). A least-squares fit of the rate data for 3 half-lives to eq 5 afforded the effective rates of equilibration at 175, 200, and 250 °C. [Plots of  $\log (A - A_{eq})$  vs.  $t$  were linear only for 3 half-lives.]

A plot of  $\ln k_{eff}$  vs.  $1/T$  and a least-squares fit to the linear Arrhenius equation gave an activation energy,  $E_a = 21.9$  kcal/mol, from the slope, and a frequency factor,  $\ln A = 13.37$ , from the intercept. By means of the Eyring equation,  $K = \kappa(k_b T/h) \exp(-\Delta G^\ddagger/RT)$ , the free energy of activation was computed at the three temperatures, assuming that the transmission coefficient,  $\kappa$ , was 1. A least-squares fit to  $\Delta G^\ddagger = \Delta H^\ddagger - T\Delta S^\ddagger$  provided  $\Delta S^\ddagger = -35.2$  eu,  $\Delta H^\ddagger = 20.9$  kcal/mol, and  $\Delta G^\ddagger_{25} = 31.4$  kcal/mol. The estimated error for  $\Delta G^\ddagger$  is 6–8%.

The Arrhenius parameters can be used to obtain  $\Delta H^\ddagger$  and  $\Delta S^\ddagger$  by  $\Delta H^\ddagger = E_a - RT$  and  $\Delta S^\ddagger = R[\ln(ha/\kappa k_b T) - 1]$ . In this manner  $\Delta H^\ddagger_{25} = 21.3$  kcal/mol and  $\Delta S^\ddagger_{25} = 42$  eu, and  $\Delta G^\ddagger_{25} = 33.8$  kcal/mol, which corresponds fairly well with the values obtained by the other method, especially considering that measurements were obtained at only three

different temperatures. The  $\Delta G^\ddagger$  values at  $T$  (175, 200, and 225 °C), calculated from the Eyring equation, are 36.6, 36.6, and 38.4 kcal/mol, respectively (from  $k_{eff} \times 10^5 = 1.34, 4.58, \text{ and } 16.0$ , respectively).

**Identification of 7b.** Phosphine **7a**<sup>16a</sup> (150 mg) and biphenyl-*d*<sub>10</sub> (250 mg, <sup>13</sup>C NMR lock substance) were dissolved in 1,2,4-trichlorobenzene (1.5 mL). The solution was sealed in vacuo in a 10-mm NMR tube, following three freeze–thaw cycles, and heated at 210 °C for 40 h. <sup>1</sup>H and <sup>13</sup>C NMR spectra were recorded before and after heating. After heating the solution, both spectra disclosed the presence of **7b**. <sup>1</sup>H NMR integration of the *tert*-butyl singlets [ $\delta$  0.55 (**7a**) and 0.78 (**7b**)] gave an isomer ratio of 83:17. <sup>13</sup>C NMR peaks are given in Table V.

A 0.5-mL portion of the solution of **7a** and **7b** was combined with 1 mL of CH<sub>2</sub>Cl<sub>2</sub> and stirred with 0.5 mL of 3% H<sub>2</sub>O<sub>2</sub> for 8 h.<sup>16a,79</sup> TLC [ethyl acetate–hexane, 1:1; 250  $\mu$ , 5  $\times$  20 cm silica gel GF (Analtech)] indicated no starting material and showed the presence of isomeric oxides **6** and **5** in ca. a 4:1 ratio, respectively (iodine stain). This was verified by comparison with authentic samples<sup>16a</sup> [ $R_f$  0.40 (pure **6**);  $R_f$  0.47 (pure **5**); mixture,  $R_f$  0.41, 0.46 (4:1 mixture)] and TLC of the mixture spiked with authentic **6** and **5**. GLC (6 ft  $\times$   $1/8$  in. glass column packed with 1.35% OV-17 on Chromosorb W HP; 200–240 °C at 2 °C/min) showed **6** and **5** in an 85:15 ratio ( $R_f$  14.7 and 14.1 min, respectively), which was confirmed by coinjection of authentic<sup>16a</sup> **6** and **5**.

**Nuclear Overhauser Experiment on 13.** The NOE experiment was performed on a Varian HA-100 spectrometer using a frequency-sweep mode. A sample of **13** was prepared as a 10% solution in C<sub>6</sub>D<sub>6</sub>. The sample was degassed by three freeze–thaw cycles in vacuo, and the tube was sealed under vacuum. The NOE enhancements were measured as area increases by electronic integration. Reference-area measurements from the normal spectrum were determined with the second rf field turned on but directed at a position far away from any proton absorptions (100 Hz upfield of Me<sub>4</sub>Si). The NOE spectrum was determined with the oscillator centered on the *P*-methyl doublet. Irradiation of the *P*-methyl group caused ~7% enhancement in the intensity of the axial 4,6 protons relative to the presumably unaffected equatorial 5-methyl group. An error of  $\pm 2\%$  in the area measurements is expected. The equatorial 4,6 protons could not be viewed since the *P*-methyl signal was too close to that absorption.

**Acknowledgment.** We thank the Petroleum Research Fund, administered by the American Chemical Society, for partial support of this work. We are indebted to Ms. Carol Folk (University of Pennsylvania) for <sup>31</sup>P and 100-MHz <sup>1</sup>H NMR spectra and to Mr. Martin Mutter and Ms. Roberta Accchione for <sup>1</sup>H and <sup>13</sup>C NMR spectral data. We also acknowledge the University of Pennsylvania for 220-MHz and 250-MHz <sup>1</sup>H NMR spectra.

**Supplementary Material Available:** Table of IR spectral data for 1,3,2-dithiaphosphorinane derivatives; table of mass spectral data on tricoordinate 1,3,2-dithiaphosphorinanes; table of miscellaneous <sup>1</sup>H NMR data for 1,3,2-dithiaphosphorinane derivatives; experimental description for the preparation of dithiols and acyclic thiophosphines; table of endocyclic torsion angles characterizing the heterocyclic ring conformations in **5**, **6**, **7a**, **11b**, **19**, **20a**, **22**, **23**, **24**, **28**, and **31**; table of <sup>31</sup>P NMR chemical shifts; discussion of <sup>31</sup>P NMR data; table of physical and analytical data for 1,3,2-dithiaphosphorinanes, including **21** (27 pages). Ordering information is given on any current masthead page.

(78) Frost, A. A.; Pearson, R. G., "Kinetics and Mechanism", Wiley, New York, 1953, pp 172–173.

(79) Attempts to separate mixtures of **7a** and **7b** (85:15) by TLC (silica gel or alumina) or by GLC were unsuccessful.